



Our **Solar Post-Top's sleek design** is the perfect solution for Urban lighting. It meets a wide range of application needs from pathways, parks to compounds and so on as well as blends harmoniously into a wide variety of architectural contexts. Engineered to perform like conventional post top lighting, Solux Solar Post- Tops feature high-performing LEDs fueled by Solar energy.

NOMINAL FLUX.....3920 LUMENS
NOMINAL POWER.....20 WATTS

LIGHTING

Efficiency.....196 Lumens/Watts
 Chips LED.....**PHILIPS** Luxeon 30-30 / 2300K to 6500K
 LED lifetime.....Over 100 000 hours LM80
 Optics/CCT.....T-III / T-V -- 2300 to 6500K
 Recommended Installation Height.....From 9.8 to 16.4 feet

BATTERY

Technology.....Lithium Iron Phosphate LIFEPO4
 Capacity.....320 Wh
 Autonomy.....Over 24 hours at full charge - 4 Rainy Days back up
 Charging time.....6-7 hours
 Lifespan.....Over 5000 CYCLES @ 80% DOD over 10 years Lifetime
 Working temp.....14°F to 158 °F - (optional -40°F TO 158 °F)

ENERGY

Solar panel.....45 Watts /18V
 Cells type.....Monocrystalline Panel Grade A 25 years
 Certificates.....IEC 61215 - IEC 61730 I and II - IEC 60904

ELECTRONIC

Controller.....MPPT SMART CONTROLLER
 Sensor.....Microwave 360° Motion Sensor
 Cabling.....Waterproof Connector, Plug and Play
 Protection.....Battery Management System (BMS)

MECHANICAL

Pole mounting.....2.9 Inches
 Material.....Aluminium and Stainless Steel

DIMENSIONS

Product.....D 23.6 x H 18.5 Inches
 Carton size.....26.7 x 26.7 x 22 Inches
 Net Weight.....22.2 Lbs
 Gross Weight.....29.7 Lbs
 Qty /Ctn 20"/40".....96/204

Model Number.....AVS-PL9510
SKU.....786703

Beyond Solar retains the right to modify or change product specifications without prior notice, as part of our ongoing commitment to improvement.



CERTIFICATIONS > IEC / TUV / EMC / LM-79- 08 and LM-80 test standards / IK8 / IP65 / CE / ULOR

Beyond Solar offers a 5 Year Limited Warranty for Post Top-Series luminaire shall be free from defects in material and workmanship for up to five (5) years from date of shipment. This limited warranty covers all components when installed and operated according to Beyond Solar instructions. Fixture suitable for ambient temperature from 14° to 122°. PV Panels - 20 year performance warranty Controller & Batteries : 5 years



LUMINAIRE HOUSING & LEDS

3920 LUMENS - 2300 TO 6500 K

High pressure die-cast low-copper aluminum. **Protection class (IP65)**. Beyond Solar uses a high quality Polyester Powder Coating from **AKZO NOBEL**. This powder coating provides an excellent salt and humidity resistance as well as ultra violet resistance for color retention for this product.

Our Luminaire is equipped with **PHILIPS LUXEON HE PLUS** High efficiency Chips offering an overall **196 Lumens per Watt efficacy**.

Our luminaire also complies with the **DARK SKY** requirement for light pollution with an **Upward lighting of 0,71%**.



DIFFERENT OPTICS*

Our different optics will allow you to optimize the lighting results of your projects

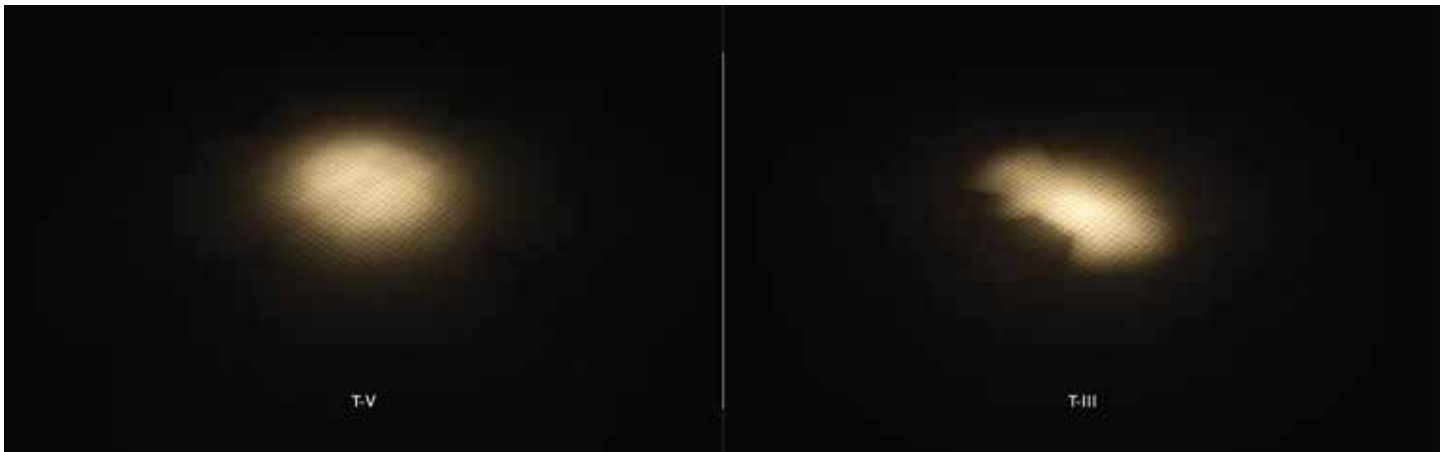

LIGHT DISTRIBUTION CURVES

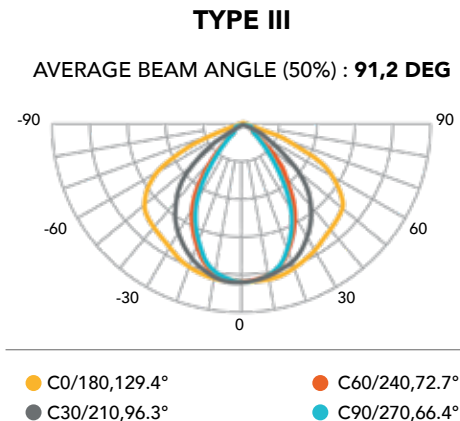
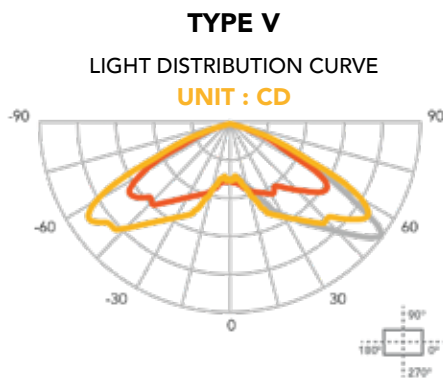

BATTERY LIFEPO4

+ OVER 10 YEARS LIFETIME

The **POST-TOP** Series is equipped with Iron **Phosphate Lithium LiFePo4** battery. This technology is proved to be the **best chemical technology for solar application on the market.**

With a cycle life of **over 3000 Cycles @ 80% DOD**, the battery enjoys **over 10 years lifetime.**



EXTREME TEMPERATURE -10 °C TO 70 °C (-40 °C OPTIONAL)

When Standard Lithium LiFePo4 batteries enjoy a working temperature range from **14°F TO 158 °F**. Beyond Solar offers as optional a new Special LIFEPO4 battery with working range of **-40 °F. to 158 °F.**

BMS ELECTRONIC PROTECTION BATTERY MANAGEMENT SYSTEM

Our batteries are equipped with **electronic circuit boards for a higher protection**, ensuring battery functioning optimization no matter the situation.



THE BMS PROTECTS AGAINST

- OVER/UNDER CURRENT • OVERLOAD • OVER/UNDER VOLTAGE • OVER/UNDER CHARGE • TEMPERATURE MANAGEMENT

COMPARISON OF DIFFERENT BATTERY TECHNOLOGIES

LIFETIME & CYCLES AT 50% DOD*

Comparisons of different battery technologies



Lead Acid
200



NimH
700



Lithium ION
800



Lithium LifePO4
3000

CHARGING TEMPERATURE RANGE WITHOUT CAPACITY LOSS

Minimum & Maximum temperature range for Optimal charging during the day

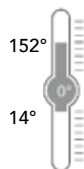

Lead Acid

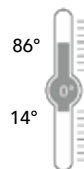

NimH



Lithium ION

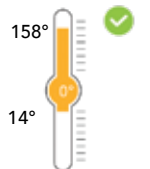

Lithium LifePO4

SOLAR PANEL

45 WATTS

High efficiency mono-crystalline **Solar panels**. Carefully selected Grade A Solar cells. Up to 20.4% efficiency, all protected by self-cleaning **tempered glass at 30 degrees** of inclination.

They are also equipped with fully **waterproof Plug and Play connectors** for easy maintenance.

OUR PV PERFORMANCE GUARANTEE

Guarantee module performance

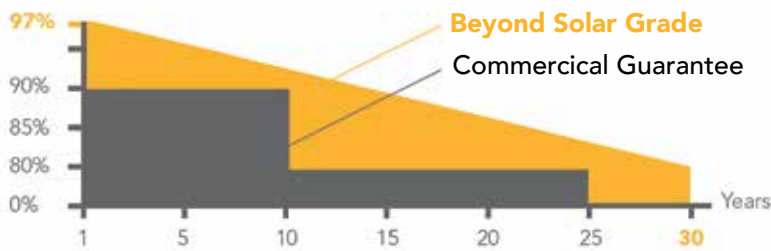

Solar Cells
GRADE 'A'

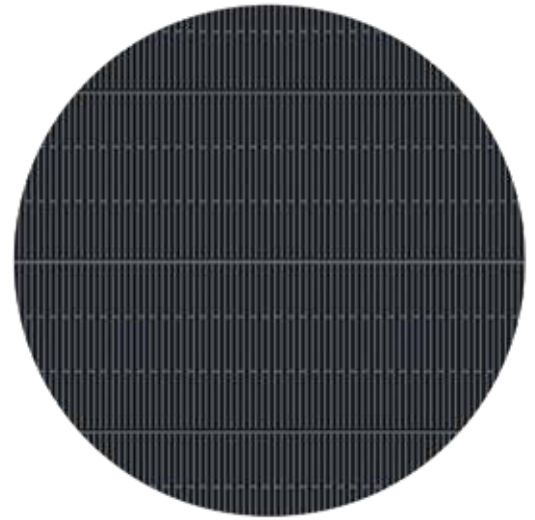

CONTROLLER MPPT



+ WATERPROOF CONNECTORS "PLUG & PLAY"

All our components are assembled **seamless and easy to access**

In a search for performance and reliability, our products are equipped with MPPT technology controller offering the best charging efficiency on the market up to 98%

REMOTE CONTROL MONITORING

In order to facilitate all maintenance operations and above all to diagnose any possible problem, without having to intervene mechanically on the luminaire, **Beyond Solar luminaires are equipped with a wireless diagnostic system via remote control.**



With a simple click it is possible to have real-time information such as:

- Automatic diagnosis in case of malfunction
- State of charge and battery histor
- Real Time load and solar panel energy production history
- Age of the product and installation
- Temperature and its history

FEATURES

Minimal stand-by power consumption
Current consumption $\leq 10\text{mA}$
Intelligent battery management

3 Phases charging:

- Charge MPPTT
- Constant voltage
- Floating voltage

Intelligent LED driver Auto detecting of dusk and dawn for automatic operation, 7 lighting programs configuration.

ANTI BLACK OUT: Load adjust according to battery capacity assuring all night long lighting in any weather conditions.

The controller also acts against:

- OVERLOAD
- OVERCURRENT
- OVERTEMPERATURE
- OVERVOLTAGE / OVERLOAD
- OVERDISCHARGE

MOTION SENSOR MICROWAVE

Our Solar Post-Top comes with microwave motion sensors that detect pedestrians, cyclists and vehicles. The light level increases as they pass to ensure safety and security while respecting the environment.



OPERATION MODE & LIGHTING SCHEDULE

In addition to automatic switching on and off, you have the possibility of choosing among different modular operating modes according to the needs of the project

Remote not included with purchase; provided only upon request for custom settings.

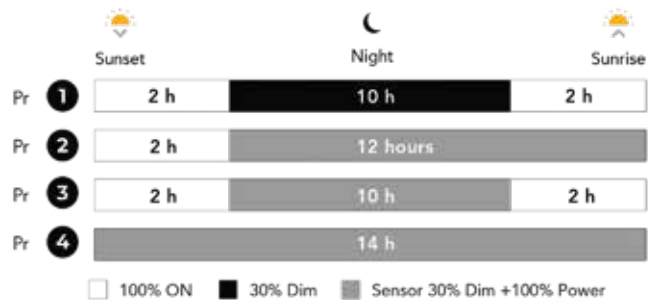

CONTACT US FOR MORE PROGRAM OPTIONS

EASY INSTALLATION

NO CABLING
NO TRENCHING

No cabling or teaching is required, **Easy to install.**
Insert on pole and switch ON.



DIMENSIONS*

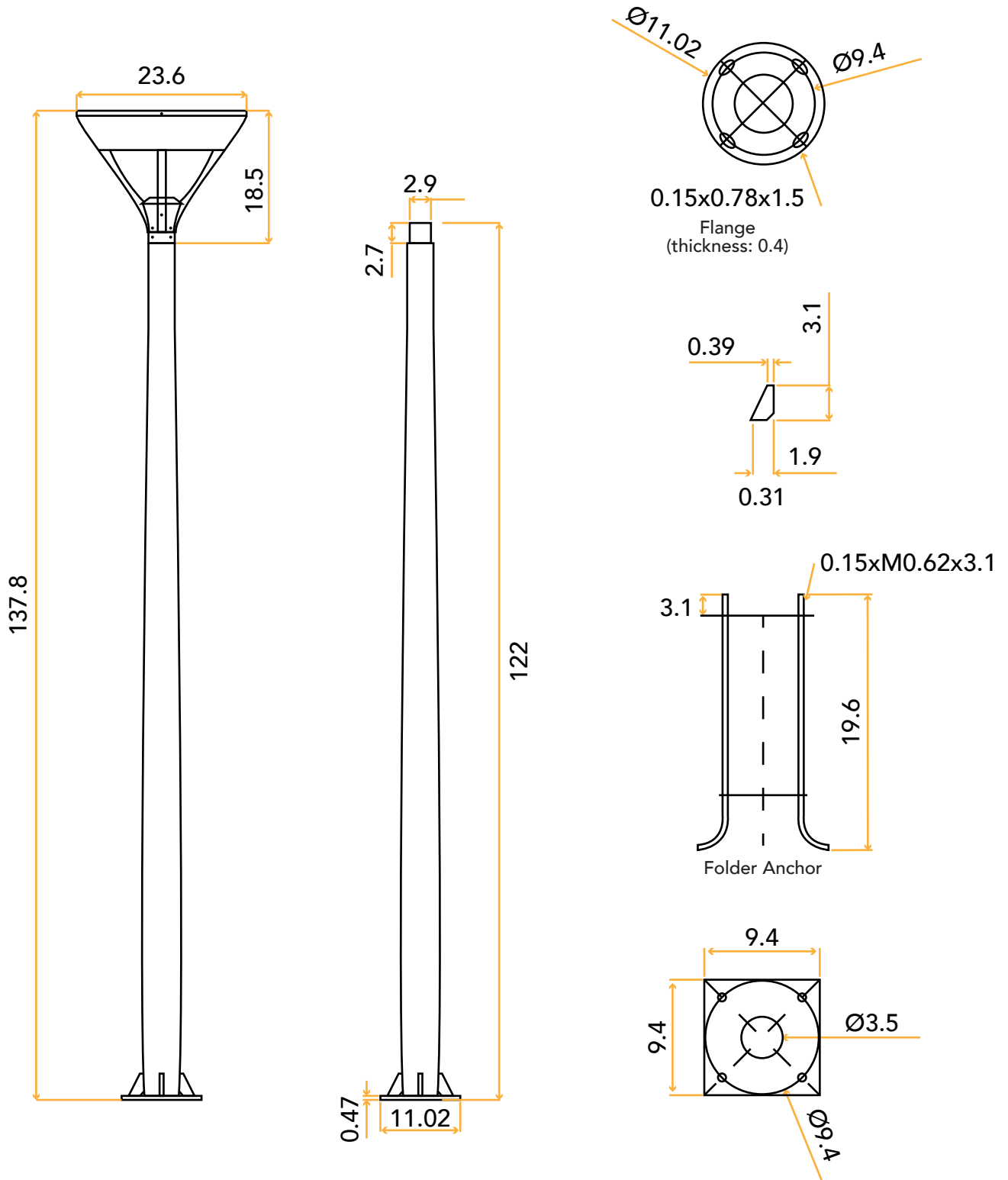

Note:

1. Unit: All dimensions are in inches
2. Ground cage: hot dip galvanized
3. 304 Nut Washer, Basic cover: 0.05 Inch 304 stainless steel plate
4. Welding as per GB985-88, Others as per contract requirements