



珠海三泰克科技有限公司  
San Technology (Zhuhai) Co., Ltd.

# SPECIFICATION FOR LCD Module

Customer P/N:

Santek P/N: ST0350H1W-RSLW-F

DOC. Revision: RS01

Customer Approval:

--

	SIGNATURE	DATE
PREPARED BY	Jerry Yang	2023-5-25
CHECKED BY	Andy Song	2023-5-26
APPROVED BY	<i>Natty Lee</i>	2023.May.29

## Document Revision History

Version	Revise Date	Description	Changed by
RS01	2023-05-25	First issue	Jerry Yang

---

## Table of Contents

1.	GENERAL DESCRIPTION	4
2.	BLOCK DIAGRAM	5
3.	MECHANICAL DRAWING	6
4.	PIN DESCRIPTION	7
5.	ABSOLUTE MAXIMUM RATINGS	8
6.	ELECTRICAL SPECIFICATIONS	8
7.	OPTICAL CHARACTERISTICS	9
8.	DATA INPUT CHARACTERISTICS	13
9.	ENVIRONMENTAL/RELIABILITY TEST	14
10.	INSPECTION CRITERIA	15
11.	SUGGESTIONS FOR USING LCD MODULES	21

## 1. General Description

### 1.1 Description

ST0350H1W-RSLW-F is a color active matrix TFT LCD Q-Panel using amorphous silicon TFT's (Thin Film Transistors) as an active switching devices. This module has a 3.5 inch diagonally measured active area with QVGA resolutions (320 horizontal by 240 vertical pixel array). Each pixel is divided into RED, GREEN, BLUE dots which are arranged in vertical stripe and this module can display 16.7M colors.

### 1.2 General Specification

Item	Specification	Units
LCD Type	3.5	inch
Resolution	320*240	dots
Color Filter Array	RGB Vertical Stripe	-
Display Mode	Normally Black, Transmissive	-
Viewing Direction	All Direction	-
Drive IC	ST7272A-G4-1-H1	-
Interface	RGB 24-bit	-
Display Number of Colors	16.7M	-
Module Size	76.84(W) x 63.84(H) x 3.15(D)	mm
Active Area	70.08(W) x 52.56(H)	mm
Pixel Pitch	0.219(W) x 0.219(H)	mm
Operating Temperature	-20~70	°C
Storage Temperature	-30~80	°C

Note: Please refer to the mechanical drawing.

## 2. Block Diagram

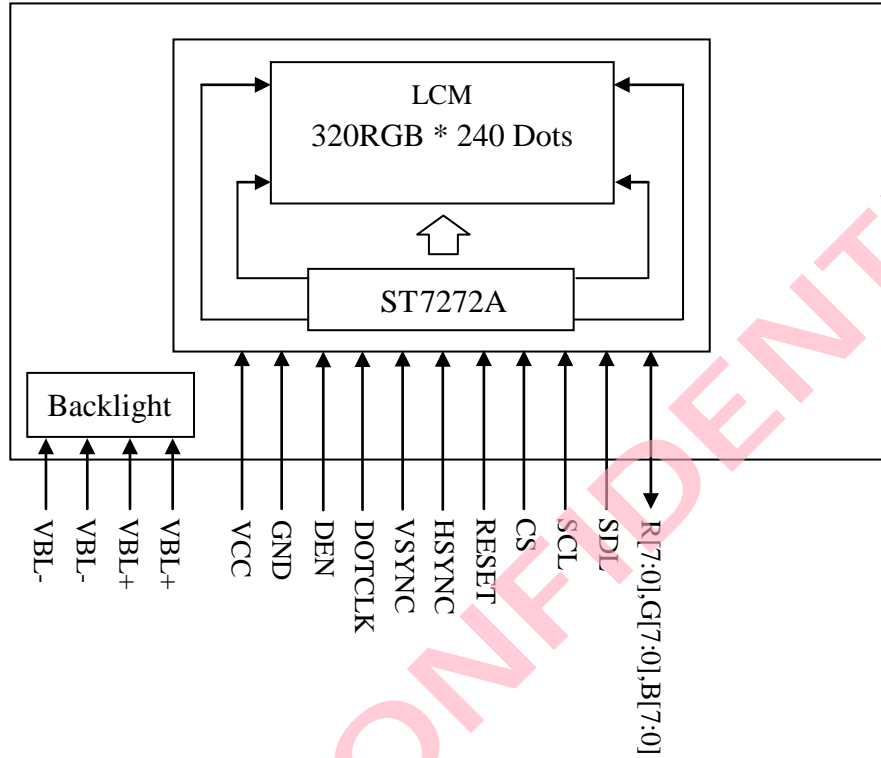



## 4. Pin Description

Pin No.	Symbol	I/O	Description
1,2	VBL-	P	Backlight LED cathode
3,4	VBL+	P	Backlight LED anode.
5~7	NC		NC
8	RESET	I	Reset signal pin (“Low” is enable)
9	CS	I	Chip select
10	SCL	I	Serial clock.
11	SDL	I/O	Serial data
12-19	B0~B7	I	Data bus
20-27	G0~G7	I	Data bus
28-35	R0~R7	I	Data bus
36	HSYNC	I	Line synchronous signal
37	VSYNC	I	Frame synchronous signal
38	DOTCLK	I	Dot-clock signal and oscillator source
39-40	NC		NC
41-42	VCC	P	Power supply for logic operation
43-47	NC		NC
48	NC		NC
49	NC		NC
50	NC		NC
51	NC		NC
52	DEN	I	Display enable signal
53-54	GND	P	System ground

Note:

I: input.  
O: output.  
P: power.

## 5. Absolute Maximum Ratings

ITEM	SYMBOL	Rating	Unit
Power Supply Voltage	VDD	- 0.3 ~ +4. 0	V
IO Supply Voltage	VDDI	- 0.3 ~ +4. 0	V
Charge Pump Supply Voltage	PVDD	- 0.3 ~ +4. 0	V
Logic Input Voltage Range	VIN	-0.3 ~ VDDI + 0.3	V
Logic Output Voltage Range	VOUT	-0.3 ~ VDDI + 0.3	V

Note 1: That the stress exceeds the Limiting Value listed above it may cause the driver IC permanent damage. These values are for stress only.

IC should be operated under the DC/AC Characteristic conditions for normal operation. If these conditions are not met, IC operation may be error and the reliability may be deteriorated.

Note 2: Parameters are valid over operating temperature range unless otherwise specified. All voltages are with respect to VSS unless otherwise noted.

Note 3: Insure the voltage levels of VDDI, VDD, PVDD always matches the correct relation:

$$1.65V \cong VDDI \cong VDD = PVDD \cong 3.6V$$

Note 4: VIN should be less than or equal to 3.6V. (VIN  $\cong$  3.6V)

## 6. Electrical Specifications

### 6.1 Recommended Operating Range

PVDD=VDD=VDDI= 3.3V, AGND= 0V, TA=25°C, Bare Chip

ITEM	SYMBOL	MIN	TYP	MAX	UNIT	Conditions
Supply Voltage	VDD	3.0	3.3	3.6	V	
Analog Power Supply Voltage	VDDI	1.65	-	3.6	V	
Charge Pump Supply Voltage	PVDD	3.0	3.3	3.6	V	

### 6.2 Backlight Driving Conditions

Parameter	Symbol	Condition	Min.	Typ.	Max.	Unit	Note
Forward Current	IF	-		40		mA	Note 1
Forward voltage	VF	IF=40mA	8.4	9.0	9.6	V	
Uniformity	$\triangle$	IF=40mA	80		-	%	
Luminance (on the module surface, BM-7)	LV	IF=40mA	280	350	-	cd/m <sup>2</sup>	
LED life time	-	IF=40mA	30,000	-	-	Hr	Note 2

Note 1: Constant current driving method.

The LED Supply Voltage is defined by the number of LED at Ta=25°C and IF =40mA.

Note 2: The "LED life time" is defined as the module brightness decrease to 50% original brightness at Ta=25°C and IF =40mA. The LED lifetime could be decreased if operating IF is larger than 40mA.

## 7. Optical Characteristics

Items	Symbol	Condition	Specifications			Unit	
			Min.	Typ.	Max.		
Contrast Ratio	CR		500	800	-	-	
Response Time	$T_{R+T_F}$		-	30	40	ms	
Luminous Intensity			280	350	-	cd/m <sup>2</sup>	
NTSC Ratio			55	60	-	%	
Viewing Angle	Ver.	$\Phi=0^\circ$	Center CR $\geq$ 10	70	80	-	deg.
		$\Phi=180^\circ$		70	80	-	
		$\Phi=90^\circ$		70	80	-	
		$\Phi=270^\circ$		70	80	-	
Reproduction of color	White	$W_x$		0.247	0.297	0.347	-
		$W_y$		0.292	0.342	0.392	-
	Red	$R_x$		0.581	0.631	0.681	-
		$R_y$		0.293	0.343	0.393	-
	Green	$G_x$		0.291	0.341	0.391	-
		$G_y$		0.550	0.600	0.650	-
	Blue	$B_x$		0.094	0.144	0.194	-
		$B_y$		0.054	0.084	0.114	-

Note:

1: Definition of Contrast Ratio (CR):

The contrast ratio can be calculated by the following expression.

CR = Surface reflectance with all white pixel/Surface reflectance with all black pixels.

2: Definition of Response Time (TR, TF):

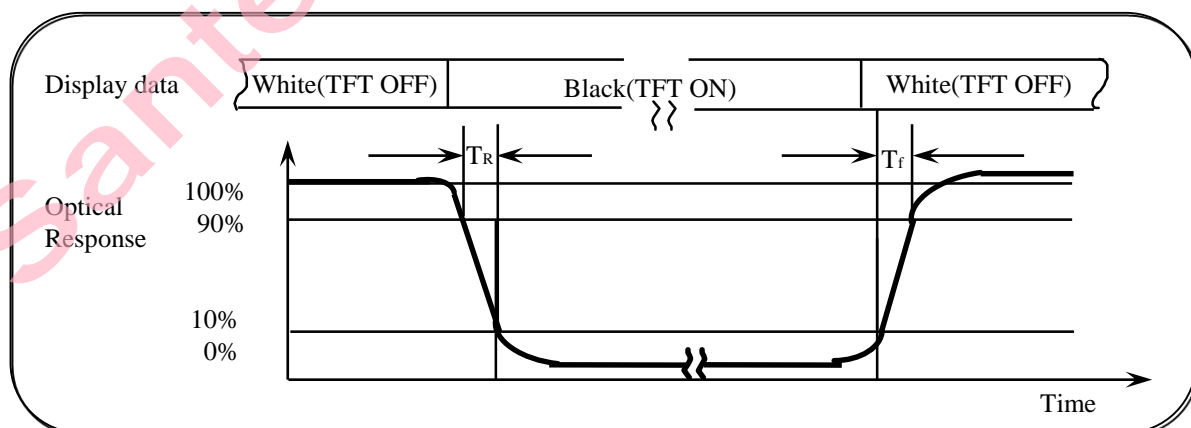

### 3: Viewing Angle

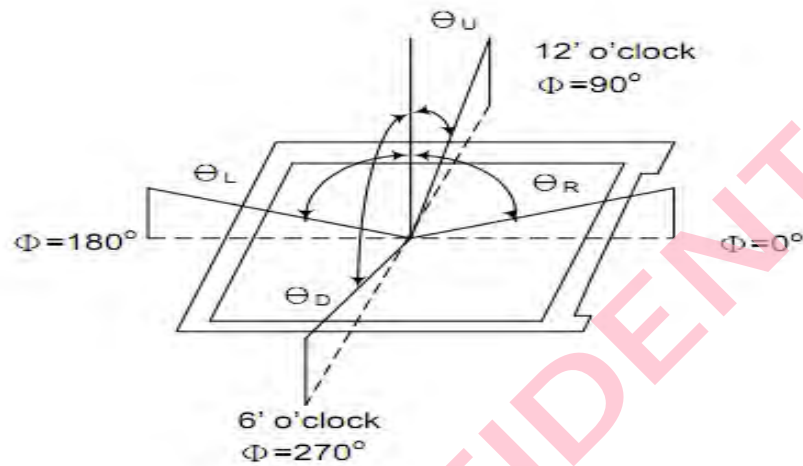

### 4: Measurement Set-Up:

The LCD module should be stabilized at a given temperature for 20 minutes to avoid abrupt temperature change during measuring. In order to stabilize the luminance, the measurement should be executed after lighting Backlight for 20 minutes in a windless room.

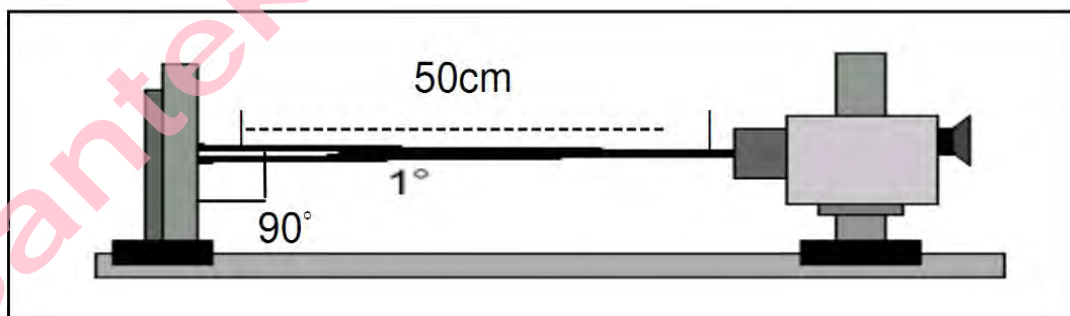

## 8. Data Input Characteristics

### 8.1 Parallel RGB Interface(SYNC mode)

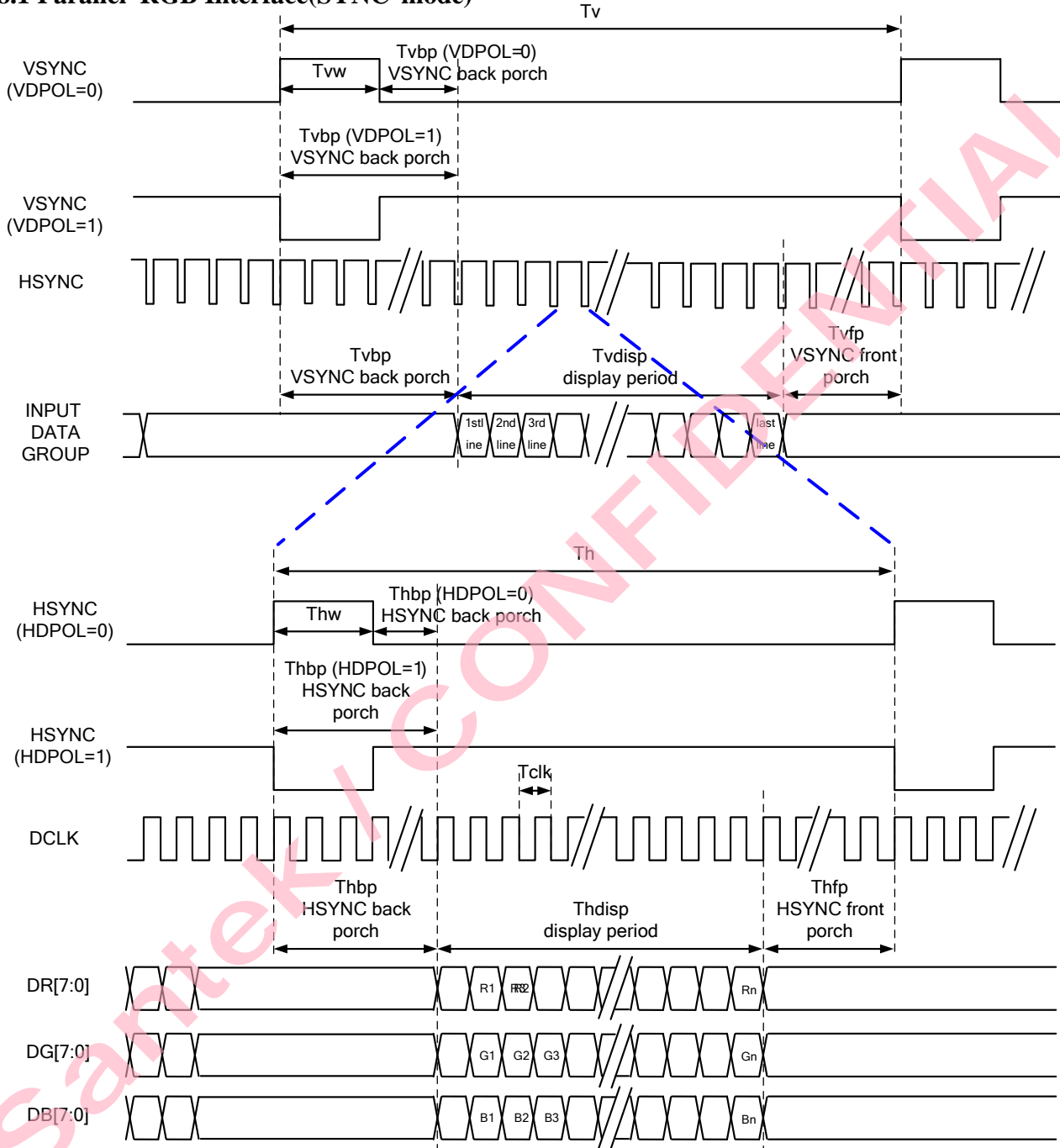

Parallel RGB Input Signal Timing(SYNC mode)

Parameter	Symbol	Min.	Typ.	Max.	Unit.	Note
DCLK Frequency	1/tDCLK	-	6.5	10	MHz	
Horizontal Period	th	-	408	-	tDCL	
Horizontal Display Period	thd	320	320	320	tDCL	
Horizontal Back Porch	thb	-	68	-	tDCL	
Horizontal Front Porch	thf	-	20	-	tDCL	
Horizontal Pulse Width	thp	1	-	-	tDCL	
Vertical Period	tv	-	-	-	th	
Vertical Display Period	tvd	240	240	240	th	
Vertical Back Porch	tvb	-	18	-	th	
Vertical Front Porch	tvf	-	4	-	th	
Vertical Pulse Width	tvp	1	-	-	th	
Data Setup Time	tsu	12	-	-	ns	
Data Hold Time	thold	12	-	-	ns	

## 8.2 Serial Peripheral Interface(SPI)

The SPI is available through the chip select line (CSB), serial transfer clock line (SCK), serial data input (SDI), and serial data output (SDO).

The Driver IC recognizes the start of data transfer at the falling edge of CSB input to initiate the transfer of start byte. It recognizes the end of data transfer at the rising edge of CSB input. The Driver IC is selected when the 6-bit chip address in the start byte transferred from the transmission device and the 6-bit device identification code assigned to the Driver IC are compared and both 6-bit data correspond. The identification code must be 011100 (Primary SPI Register) or 011101 (Secondary SPI Register). Two different chip addresses must be assigned to the Driver IC because the seventh bit of the start byte is assigned to a register select bit (RS). When RS = 0, index register write or status read is executed. When the RS=1, instruction write. The eighth bit of the start byte is to specify read or write (R/W bit). The data are received when the R/W bit is 0, and are transmitted when the R/W bit is 1.

After receiving the start byte, the Driver IC starts to transmit or receive data by byte. The data transmission adopts a format by which the MSB is first transmitted (9th SCK started). All Driver IC instructions consist of 16 bits and they are executed internally after two bytes are transmitted with the MSB first (IB15 to 0---9th ~24th SCK).

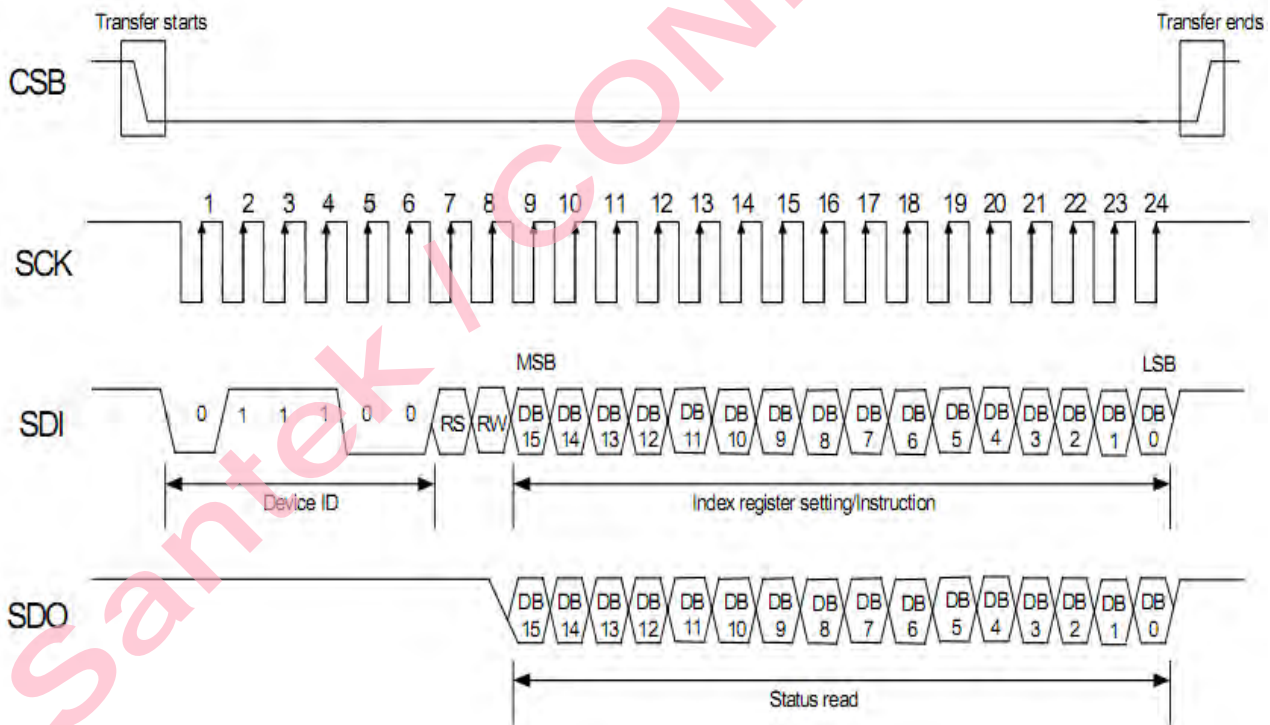

SPI Interface Input Signal Timing

## 9. Environmental / Reliability Test

### 9.1 Temperature and Humidity

Test Item	Test Condition	Test result determinant gist
High temperature storage	80±2℃;240H	Inspection after 2~4hours storage at room temperature, the sample shall be free from defects: After the test, the test has been done The LCD sample must be at normal indoor temperature and humidityPlace in the environment for more than 2 to 4 hours to enterLine function and appearance inspection, samples are not allowed to haveThe damage: 1.Air bubble in the LCD; 2.Sealleak; 3.Non-display; 4.Missing segments; 5.Glass crack; 6.Current Idd is twice higher than initial value. 7.The surface shall be free from damage. 8.The electrical characteristics requirements shall be satisfied.
Low temperature storage	-30±2℃;240H	
High temperature operation	70±2℃;240H	
Low temperature operation	-20±2℃;240H	
Damp Proof Test	60℃±3℃,90%±3%RH;240H	
Temperature Shock	-10±2℃,60min→60±2℃,60min; 10cycle	
Vibration Test	Frequency: 10Hz~55Hz~10Hz Amplitude: 1.5mm, X, Y, Z direction for total 0.5hours(Packing condition)	

Note:

1. The test samples should be applied to only one test item.
2. Sample size for each test item is 2pcs.
3. For Damp Proof Test, Pure water(Resistance>10MΩ) should be used.
4. In case of malfunction defect caused by ESD damage, if it would be recovered to normal state after resetting, it would be judged as a good part.

### 9.2 Electrostatic Discharge(with BL)

Test Item	Test Condition	Remark	
ESD	150pF, 330Ω, Contact:±4KV,Air:±8KV	1	Class B
	200pF, 0Ω, ±200V contact test	2	

Test Point

1. LCD glass and metal bezel.
2. If connector pins.
3. ESD class B:some performance degradation allowed. Self-recoverable.  
No data lost,no hardware failures.

## 10. Inspection Criteria

### 10.1 Scope

The incoming inspection standards shall be applied to TFT –LCD Modules(hereinafter called "Modules") that supplied by ZhuHai Santek.

### 10.2 Incoming Inspection

The customer shall inspect the modules within twenty calendar days of the delivery date (the “inspection period”) at its own cost. The result of the inspection (acceptance or rejection) shall be recorded in writing, and a copy of this writing will be promptly sent to the seller. If the results of the inspecting from buyer does not send to the seller within twenty calendar days of the delivery date. The modules shall be regards as acceptance. Should the customer fail to notify the seller within the inspection period, the buyers right to reject the modules. Shall be lapsed and the modules shall be deemed to have been accepted by the buyer.

### 10.3 Inspection Sampling Method

10.3.1. Lot size: Quantity per shipment lot per model.

10.3.2. Sampling type: Normal inspection, Single sampling.

10.3.3. Acceptable quality level(AQL) .

Major defect: AQL=0.65.

Minor defect: AQL=1.00.

### 10.4 Inspection Conditions:

10.4.1. Ambient conditions:

a. Temperature: Room temperature  $25\pm 5^{\circ}\text{C}$ .

b. Humidity:  $(60\pm 10)\% \text{RH}$ .

c. Illumination: Single fluorescent lamp non-directive (300 to 700 Lux).

10.4.2. Viewing distance:

The distance between the LCD and the inspector’s eyes shall be at least 35~40cm.

10.4.3. Viewing angle:

U/D:  $45^{\circ}/45^{\circ}$ , L/R:  $45^{\circ}/45^{\circ}$ .

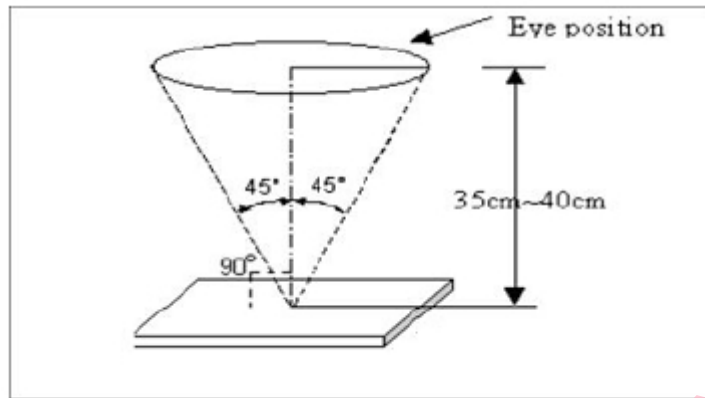

**10.5 Defects are classified as major defects and minor defects according to the degree of defectiveness defined herein.**

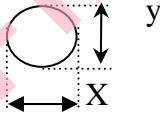
No	Item	Criterion for defects	Defect type																																														
1	Black/white spot defect (in displaying)	<p>Black/white spot definition</p> $\Phi = (x+y)/2$  <p>1. Black/white spot defect (<math>\leq 4.0</math>inch)</p> <table border="1"> <thead> <tr> <th rowspan="2">area size (mm)</th> <th colspan="3">Acceptable number</th> </tr> <tr> <th>A</th> <th>B</th> <th>C</th> </tr> </thead> <tbody> <tr> <td><math>\Phi \leq 0.1</math></td> <td colspan="3">ignore</td> </tr> <tr> <td><math>0.1 &lt; \Phi \leq 0.15</math></td> <td colspan="3">3</td> </tr> <tr> <td><math>0.15 &lt; \Phi \leq 0.25</math></td> <td colspan="3">2</td> </tr> <tr> <td><math>\Phi &gt; 0.25</math></td> <td colspan="3">0</td> </tr> </tbody> </table> <p>2. Black/white spot defect (<math>&gt; 4.0</math>inch)</p> <table border="1"> <thead> <tr> <th rowspan="2">area size (mm)</th> <th colspan="3">Acceptable number</th> </tr> <tr> <th>A</th> <th>B</th> <th>C</th> </tr> </thead> <tbody> <tr> <td><math>\Phi \leq 0.15</math></td> <td colspan="3">ignore</td> </tr> <tr> <td><math>0.15 &lt; \Phi \leq 0.25</math></td> <td colspan="3">2</td> </tr> <tr> <td><math>0.25 &lt; \Phi \leq 0.35</math></td> <td colspan="3">1</td> </tr> <tr> <td><math>\Phi &gt; 0.35</math></td> <td colspan="3">0</td> </tr> </tbody> </table>	area size (mm)	Acceptable number			A	B	C	$\Phi \leq 0.1$	ignore			$0.1 < \Phi \leq 0.15$	3			$0.15 < \Phi \leq 0.25$	2			$\Phi > 0.25$	0			area size (mm)	Acceptable number			A	B	C	$\Phi \leq 0.15$	ignore			$0.15 < \Phi \leq 0.25$	2			$0.25 < \Phi \leq 0.35$	1			$\Phi > 0.35$	0			Minor
area size (mm)	Acceptable number																																																
	A	B	C																																														
$\Phi \leq 0.1$	ignore																																																
$0.1 < \Phi \leq 0.15$	3																																																
$0.15 < \Phi \leq 0.25$	2																																																
$\Phi > 0.25$	0																																																
area size (mm)	Acceptable number																																																
	A	B	C																																														
$\Phi \leq 0.15$	ignore																																																
$0.15 < \Phi \leq 0.25$	2																																																
$0.25 < \Phi \leq 0.35$	1																																																
$\Phi > 0.35$	0																																																

2	Black/white line defect (in displaying)	1. Black/white line defect (All inch)					Minor
		size (mm)		Acceptable number			
		L(length)	W(width)	area			
				A	B	C	
		10<L	0.03<W≤0.04	5			
		5.0<L≤10	0.04<W≤0.06	3			
1.0<L≤5.0	0.06<W≤0.07	2					
L≤1.0	0.07<W≤0.09	1			ignore		

3	Blemish & foreign matters	1. Dot ( $\leq 4.0$ inch LCD)	Minor																							
		<table border="1" style="width: 100%; border-collapse: collapse;"> <thead> <tr> <th rowspan="3" style="width: 30%;">size(mm)</th> <th colspan="3">Acceptable number</th> </tr> <tr> <th colspan="3">area</th> </tr> <tr> <th style="width: 15%;">A</th> <th style="width: 15%;">B</th> <th style="width: 15%;">C</th> </tr> </thead> <tbody> <tr> <td><math>\Phi \leq 0.1</math></td> <td colspan="2">ignore</td> <td rowspan="4" style="text-align: center; vertical-align: middle;">ignore</td> </tr> <tr> <td><math>0.10 &lt; \Phi \leq 0.15</math></td> <td colspan="2" style="text-align: center;">2</td> </tr> <tr> <td><math>0.15 &lt; \Phi \leq 0.25</math></td> <td colspan="2" style="text-align: center;">1</td> </tr> <tr> <td><math>0.25 &lt; \Phi</math></td> <td colspan="2" style="text-align: center;">0</td> </tr> </tbody> </table>		size(mm)	Acceptable number			area			A	B	C	$\Phi \leq 0.1$	ignore		ignore	$0.10 < \Phi \leq 0.15$	2		$0.15 < \Phi \leq 0.25$	1		$0.25 < \Phi$	0	
		size(mm)			Acceptable number																					
					area																					
				A	B	C																				
		$\Phi \leq 0.1$		ignore		ignore																				
		$0.10 < \Phi \leq 0.15$		2																						
		$0.15 < \Phi \leq 0.25$		1																						
		$0.25 < \Phi$		0																						
		2. Dot ( $> 4.0$ inch LCD)																								
		<table border="1" style="width: 100%; border-collapse: collapse;"> <thead> <tr> <th rowspan="3" style="width: 30%;">size(mm)</th> <th colspan="3">Acceptable number</th> </tr> <tr> <th colspan="3">area</th> </tr> <tr> <th style="width: 15%;">A</th> <th style="width: 15%;">B</th> <th style="width: 15%;">C</th> </tr> </thead> <tbody> <tr> <td><math>\Phi \leq 0.15</math></td> <td colspan="2">ignore</td> <td rowspan="4" style="text-align: center; vertical-align: middle;">ignore</td> </tr> <tr> <td><math>0.15 &lt; \Phi \leq 0.25</math></td> <td colspan="2" style="text-align: center;">2</td> </tr> <tr> <td><math>0.25 &lt; \Phi \leq 0.35</math></td> <td colspan="2" style="text-align: center;">1</td> </tr> <tr> <td><math>\Phi &gt; 0.35</math></td> <td colspan="2" style="text-align: center;">0</td> </tr> </tbody> </table>		size(mm)	Acceptable number			area			A	B	C	$\Phi \leq 0.15$	ignore		ignore	$0.15 < \Phi \leq 0.25$	2		$0.25 < \Phi \leq 0.35$	1		$\Phi > 0.35$	0	
		size(mm)			Acceptable number																					
area																										
A	B		C																							
$\Phi \leq 0.15$	ignore		ignore																							
$0.15 < \Phi \leq 0.25$	2																									
$0.25 < \Phi \leq 0.35$	1																									
$\Phi > 0.35$	0																									
3. Blemish ( $\leq 4.0$ inch on touch panle or between touch panel ane LCD )																										
<table border="1" style="width: 100%; border-collapse: collapse;"> <thead> <tr> <th rowspan="3" style="width: 30%;">size(mm)</th> <th colspan="3">Acceptable number</th> </tr> <tr> <th colspan="3">area</th> </tr> <tr> <th style="width: 15%;">A</th> <th style="width: 15%;">B</th> <th style="width: 15%;">C</th> </tr> </thead> <tbody> <tr> <td><math>\Phi \leq 0.1</math></td> <td colspan="2">ignore</td> <td rowspan="3" style="text-align: center; vertical-align: middle;">ignore</td> </tr> <tr> <td><math>0.10 &lt; \Phi \leq 0.15</math></td> <td colspan="2" style="text-align: center;">1</td> </tr> <tr> <td><math>0.15 &lt; \Phi</math></td> <td colspan="2" style="text-align: center;">0</td> </tr> </tbody> </table>	size(mm)	Acceptable number			area			A	B	C	$\Phi \leq 0.1$	ignore		ignore	$0.10 < \Phi \leq 0.15$	1		$0.15 < \Phi$	0							
size(mm)		Acceptable number																								
		area																								
	A	B	C																							
$\Phi \leq 0.1$	ignore		ignore																							
$0.10 < \Phi \leq 0.15$	1																									
$0.15 < \Phi$	0																									

		<p>4. Blemish(&gt;4.0inch on touch panle or between touch panel ane LCD)</p> <table border="1"> <thead> <tr> <th rowspan="3">size(mm)</th> <th colspan="3">Acceptable number</th> </tr> <tr> <th colspan="3">area</th> </tr> <tr> <th>A</th> <th>B</th> <th>C</th> </tr> </thead> <tbody> <tr> <td><math>\Phi \leq 0.15</math></td> <td colspan="2">ignore</td> <td rowspan="4">ignore</td> </tr> <tr> <td><math>0.15 &lt; \Phi \leq 0.25</math></td> <td colspan="2">2</td> </tr> <tr> <td><math>0.25 &lt; \Phi \leq 0.35</math></td> <td colspan="2">1</td> </tr> <tr> <td><math>\Phi &gt; 0.35</math></td> <td colspan="2">0</td> </tr> </tbody> </table> <p>5. Lline(All inch LCD/touch panle)</p> <table border="1"> <thead> <tr> <th colspan="2">size(mm)</th> <th colspan="3">Acceptable number</th> </tr> <tr> <th rowspan="2">L(length)</th> <th rowspan="2">W(width)</th> <th colspan="3">area</th> </tr> <tr> <th>A</th> <th>B</th> <th>C</th> </tr> </thead> <tbody> <tr> <td>Ignore</td> <td><math>W \leq 0.02</math></td> <td colspan="2">5</td> <td rowspan="4">ignore</td> </tr> <tr> <td><math>L \leq 3.0</math></td> <td><math>0.02 &lt; W \leq 0.03</math></td> <td colspan="2">3</td> </tr> <tr> <td><math>L \leq 2.0</math></td> <td><math>0.03 &lt; W \leq 0.05</math></td> <td colspan="2">2</td> </tr> <tr> <td>---</td> <td><math>W &gt; 0.05</math></td> <td colspan="2">Treat with dot</td> </tr> </tbody> </table>	size(mm)	Acceptable number			area			A	B	C	$\Phi \leq 0.15$	ignore		ignore	$0.15 < \Phi \leq 0.25$	2		$0.25 < \Phi \leq 0.35$	1		$\Phi > 0.35$	0		size(mm)		Acceptable number			L(length)	W(width)	area			A	B	C	Ignore	$W \leq 0.02$	5		ignore	$L \leq 3.0$	$0.02 < W \leq 0.03$	3		$L \leq 2.0$	$0.03 < W \leq 0.05$	2		---	$W > 0.05$	Treat with dot		
size(mm)	Acceptable number																																																							
	area																																																							
	A	B	C																																																					
$\Phi \leq 0.15$	ignore		ignore																																																					
$0.15 < \Phi \leq 0.25$	2																																																							
$0.25 < \Phi \leq 0.35$	1																																																							
$\Phi > 0.35$	0																																																							
size(mm)		Acceptable number																																																						
L(length)	W(width)	area																																																						
		A	B	C																																																				
Ignore	$W \leq 0.02$	5		ignore																																																				
$L \leq 3.0$	$0.02 < W \leq 0.03$	3																																																						
$L \leq 2.0$	$0.03 < W \leq 0.05$	2																																																						
---	$W > 0.05$	Treat with dot																																																						
4	Stain on LCD panel surface	Stain which cannot be removed even when wiped lightly with a soft cloth or similar cleaning too are rejectable	Minor																																																					
5	Rust in bezel	Rust which is visible in the bezel is rejectable	Minor																																																					
6	Defect of land surface contact	Evident crevices which is visble are rejectable	Minor																																																					
7	Parts mounting	(1) Failure to mount parts (2) Parts not in the specification are mounted (3) Polarith, for example,is reversed	Major Major Major																																																					
8	Parts alignment	(1) LSI,IC lead width is more than 50% beyond pad outline (2) Chip component is off center and more than 50% of the leads is off the pad outline	Minor Minor																																																					

9	Conductive foreign matter	(1) On open space(gnd,manual solder)solder ball is allowed up to $\Phi 0.1\text{mm}$ (1EA). (2) In case of shield space is allowed up to $\Phi 0.2\text{mm}$ (1EA)	Major
10	Faculty PWB correction	(1) Due to PWB copper foil pattern burnout,the pattern is connected,using a jumper wire for repair;2 or more places corrected per PWB (2) Short circuited part is cut,and no resist coating has been performed.	Minor Minor

Area definition

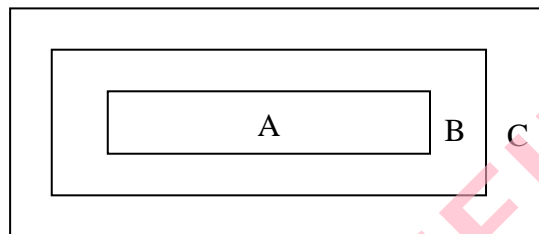

LCD inspection area

A: Active area.

B: Visible area.

C: Outside of visible area (Invisible area after assembling).

Visible Defect in area C, but it cannot affect product's quality, it is allowed.

## 11. Suggestions for using LCD modules

### 10. Handling Instruction

#### 10.1 Cautions for handling LCD panels



#### Caution

- (1) Do not make an impact on the LCD panel glass because it may break and you may get injured from it.
- (2) If the glass breaks, do not touch it with bare hands.  
(Fragment of broken glass may stick you or you cut yourself on it.)
- (3) If you get injured, receive adequate first aid and consult a medical doctor.
- (4) Do not let liquid crystal get into your mouth.  
(If the LCD panel glass breaks, try not let liquid crystal get into your mouth even toxic property of liquid crystal has not been confirmed.)
- (5) If liquid crystal adheres, rinse it out thoroughly.  
(If liquid crystal adheres to your cloth or skin, wipe it off with rubbing alcohol or wash it thoroughly with soap. If liquid crystal gets into eyes, rinse it with clean water for at least 15 minutes and consult an eye doctor.)
- (6) If you scrap this products, follow a disposal standard of industrial waste that is legally valid in the community, country or territory where you reside.
- (7) Do not connect or disconnect this product while its application products is powered on.
- (8) Do not attempt to disassemble or modify this product as it is precision component.
- (9) If a part of soldering part has been exposed, and avoid contact (short-circuit) with a metallic part of the case etc. about FPC of this model, please.  
Please insulate it with the insulating tape etc. if necessary.  
The defective operation is caused, and there is a possibility to generation of heat and the ignition.
- (10) Since excess current protection circuit is not built in this TFT module, there is the possibility that LCD module or peripheral circuit become feverish and burned in case abnormal operation is generated.  
We recommend you to add excess current protection circuit to power supply.



#### Caution

This mark is used to indicate a precaution or an instruction which, if not correctly observed, may result in bodily injury, or material damages alone.

### 11.2 Precautions for handling

- 1) Wear finger tips at incoming inspection and for handling the TFT monitors to keep display quality and keep the working area clean.  
Do not touch the surface of the monitor as it is easily scratched.
- 2) when handling the TFT monitors as the LED in this TFT monitors is damageable to electrostatic discharge. Designate an appropriate operating area, and set equipment, tools, and machines properly when handling this product.
- 3) Avoid strong mechanical shock including knocking, hitting or dropping to the TFT monitors for protecting their glass parts. Do not use the TFT monitors that have been experienced dropping or strong mechanical shock.
- 4) Do not use or storage the TFT monitors at high temperature and high humidity environment. Particularly, never use or storage the TFT monitors at a location where condensation builds up.
- 5) Avoid using and storing TFT monitors at a location where they are exposed to direct sunlight or ultraviolet rays to prevent the LCD panels from deterioration by ultraviolet rays.
- 6) Do not stain or damage the contacts of the FPC cable .  
FPC cable needs to be inserted until it can reach to the end of connector slot.  
During insertion, make sure to keep the cable in a horizontal position to avoid an oblique insertion. Otherwise, it may cause poor contact or deteriorate reliability of the FPC cable.
- 7) Do not bend or pull the FPC cable or carry the TFT monitor by holding the FPC cable.  
Especially, it will cause mechanical damage or critical defect if FPC is pull up or bent up to short of display.

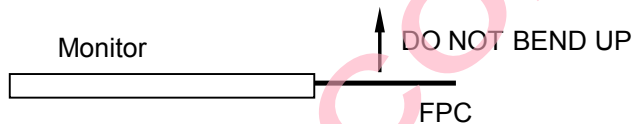

- 8) Peel off the protective film on the TFT monitors during mounting process.  
We are not responsible for electrostatic discharge failures or other defects occur when peeling off the protective film.
- 9) It is recommended to employ the structure of which polarizer peripheral area of LCD panel being pressed by cushioning materials, in order to prevent a cause of display brightness unevenness.
- 10) By reason of this model is made by thin glass, this model LCD is breakable.  
Please apply fitting of protection LCD surface. (ex. Covered acrylic board on LCD surface)

### 11.3 Precautions for operation

- 1) Since this TFT monitors are not equipped with light shielding for the driver IC, do not expose the driver IC to strong lights during operation as it may cause functional failures.
- 2) In case of powering up or powering off this LCD module, be sure to comply the sequence as instructed in this specification.
- 3) Do not plug in or out the FPC cable while power supply is switch on.  
Plug the FPC cable in and out while power supply is switched off.
- 4) Do not operate the TFT monitors in the strong magnetic field. It may break the TFT monitors.

- 5) Do not display a fixed image on the screen for a long time.  
Use a screen-saver or other measures to avoid a fixed image displayed on the screen for a long time.  
Otherwise, it may cause burn-in image on the screen due the characteristics of liquid crystal.

#### 11.4 Storage condition for shipping cartons

##### Storage environment

- Temperature 0 to 40°C
- Humidity 60%RH or less  
No-condensing occurs under low temperature with high humidity condition.
- Atmosphere No poisonous gas that can erode electronic components and/or wiring materials should be detected.
- Time period 1 year
- Unpacking To prevent damages caused by static electricity, anti-static precautionary measures (e.g. earthing, anti-static mat) should be implemented.  
After unpack, keep product in the appropriate condition, otherwise bubble seal of Protective film may be printed on Polarizer.
- Maximum piling up 5 cartons

##### \*Conditions to storage after unpacking

##### Storage environment

- Temperature 0 to 40°C
- Humidity 60%RH or less  
No-condensing occurs under low temperature with high humidity condition.
- Atmosphere No poisonous gas that can erode electronic components and/or wiring materials should be detected.
- Time period 1 year (Shelf life)
- Others