

SPECIFICATION FOR LCD Module

Customer P/N:

Santek P/N: ST1400A1-RSLW-C

DOC. Revision: RS01

Customer Approval:

--

	SIGNATURE	DATE
PREPARED BY	Vicky Li	2021-10-15
CHECKED BY	Park Zhou Andy Song	2021-10-15
APPROVED BY	<i>Natty Lee</i>	2021.Oct.15

Document Revision History

Version	Revise Date	Description	Changed by
RS01	2021-10-15	First issue	Vicky Li

Table of Contents

1. GENERAL DESCRIPTION.....	4
2. ABSOLUTE MAXIMUM RATINGS.....	6
3. ELECTRICAL SPECIFICATIONS.....	7
4. OPTICAL SPECIFICATION.....	10
5. INTERFACE CONNECTION.....	14
6. SIGNAL TIMING SPECIFICATION.....	18
7. INPUT SIGNALS, BASIC DISPLAY COLORS & GRAY SCALE OF COLORS.....	20
8. POWER SEQUENCE.....	21
9. MECHANICAL DRAWING	22
10. PACKAGE DRAWING	23
11. RELIABILITY TEST.....	24
12. HANDLING & CAUTIONS.....	25

1.0 GENERAL DESCRIPTION

1.1 Introduction

ST1400A1-RSLW-C is a color active matrix TFT LCD module using amorphous silicon TFT's (Thin Film Transistors) as an active switching devices. This module has a 14.0 inch diagonally measured active area with Full HD resolutions (1920 horizontal by 1080 vertical pixel array). Each pixel is divided into RED, GREEN, BLUE dots which are arranged in vertical stripe and this module can display 16.7M(6bit+FRC) colors and color gamut 45%. The TFT-LCD panel used for this module is a low reflection and higher color type. Therefore, this module is suitable for Smart Payment-POS PC. The LED driver for back-light driving is built in this model.

All input signals are eDP1.2 interface compatible.

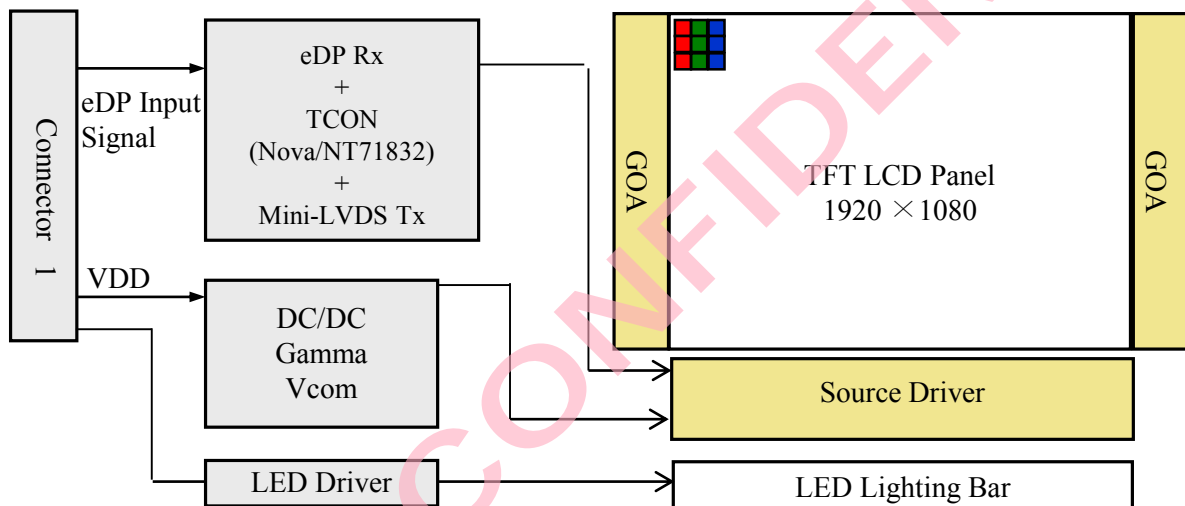

Figure 1. Drive Architecture

1.2 Features

- Thin and light weight
- 2 lane eDP interface with 2.7Gbps link rates
- 16.7M(6bit+FRC) color depth, color gamut 45%
- Data enable signal mode
- Side mounting frame
- On board LED driving circuit
- Single LED lighting bar (Bottom side/Horizontal Direction)
- Low driving voltage and low power consumption
- On board EDID chip
- Green product (RoHS & Halogen free product)

1.3 Application

- Smart Payment-POS PC

1.4 General Specification

The followings are general specifications at the model. (listed in Table 1)

<Table 1. General Specifications>

Parameter	Specification	Unit	Remarks
Active area	309.31(L) × 173.99(W)	mm	
Resolution	1920 x 3(RGB) x 1080	pixels	
Pixel pitch	53.7(L) × 161.1(W)	um	
Pixel arrangement	RGB Vertical stripe		
Display colors	16.7M(6bit+FRC)		
Color gamut	45%		
Display mode	Normally Black		
Dimensional outline	320.4(L) × 204.85(W) × 3.0(T)	mm	With PCBA
Weight	370(max)	g	
Surface treatment	Anti-Glare		
Surface hardness	3H		
Back-light	Bottom edge side, 1-LED lighting bar type		Note 1
Power consumption	P _D : 0.9	W	@Mosaic
	P _{BL} : 3.9	W	Max.
	P _{Total} : 4.8	W	@Mosaic

Notes : 1. LED Lighting Bar (60*LED Array) ;

2.0 ABSOLUTE MAXIMUM RATINGS

The followings are maximum values which, if exceed, may cause faulty operation or damage to the unit. The operational and non-operational maximum voltage and current values are listed in Table 2.

< Table 2. Absolute Maximum Ratings >

Ta=25+/-2°C

Parameter	Symbol	Min.	Max.	Unit	Remarks
Power Supply Voltage	V _{DD}	-0.3	4.0	V	Note 1
Logic Supply Voltage	V _{IN}	V _{SS} -0.3	V _{DD} +0.3	V	
Operating Temperature	T _{OP}	-10	+50	°C	Note 2
Storage Temperature	T _{ST}	-20	+60	°C	

Notes :

1. Permanent damage to the device may occur if maximum values are exceeded functional operation should be restricted to the condition described under normal operating conditions.
2. Temperature and relative humidity range are shown in the figure below.
95 % RH Max. (40 °C ≥ Ta) Maximum wet - bulb temperature at 39 °C or less. (Ta > 40 °C) No condensation.

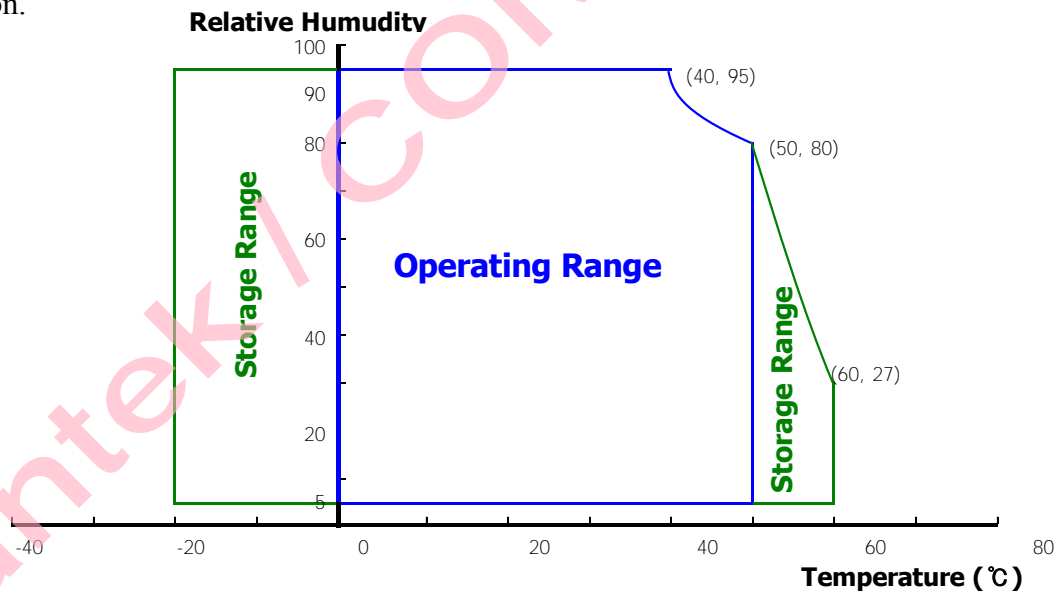

Figure 2. Temperature and Relative Humidity Range

3.0 ELECTRICAL SPECIFICATIONS

3.1 Electrical Specifications

< Table 3. Electrical Specifications >

Ta=25+/-2°C

Parameter		Min.	Typ.	Max.	Unit	Remarks
Power Supply Voltage	V _{DD}	3.0	3.3	3.6	V	Note 1
Permissible Input Ripple Voltage	V _{RF}	-	-	100	mV	@ V _{DD} = 3.3V
BIST Control Level	High Level	2	-	3.6	V	
	Low Level	0	-	0.8	V	
Power Supply Current	I _{DD}	-	273	389	mA	Note 1
Power Supply Inrush Current	Inrush	-	-	1.5	A	Note3
Power Consumption	P _D	-	0.90	1.40	W	Note 1
	P _{BL}	-	-	3.90	W	Note 2
	P _{total}	-	4.80	5.30	W	Note 1

Notes :

1. The supply voltage is measured and specified at the interface connector of LCM.

The current draw and power consumption specified is for 3.3V at 25 °C.

a) Typ : Mosaic pattern 8*8

b) Max : R/G/B patterns

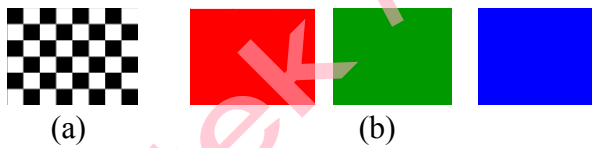

Figure 3. Power Measure Patterns

2. Calculated value for reference (V_LED × I_LED).

3. When peak current is 1.5A, V_{DD} should be more than 2.75V.

3.2 Backlight Unit

< Table 4. LED Driving Guideline Specifications >

Ta=25+/-2°C

Parameter		Min.	Typ.	Max.	Unit	Remarks
LED Forward Voltage		V _F	-	-	3	V
LED Forward Current		I _F	-	20	-	mA
LED Power Consumption		P _{LED}	-	-	3.9	W Note 1
LED Life-Time		N/A	15,000	-	-	Hour I _F = 22mA
Power Supply Voltage for LED Driver		V _{LED}	10	12	14	V
Power Supply Voltage for LED Driver Inrush		I _{led} inrush	-	-	1.5	A Note 4
EN Control Level	Backlight On		2.5	-	5.0	V
	Backlight Off		0	-	0.6	V
PWM Control Level	High Level		2.5	-	5.0	V
	Low Level		0	-	0.6	V
PWM Control Frequency		F _{PWM}	200	-	10,000	Hz
Duty Ratio			1	-	100	% Note 3

Notes :

1. Power supply voltage 12V for LED driver.
Calculator value for reference $I_F \times V_F \times 60 / \text{driver efficiency} = P_{LED}$
2. The LED life-time define as the estimated time to 50% degradation of initial luminous.
3. 1% duty cycle is achievable with a dimming frequency less than 1KHz.
4. Measure condition (Figure 5)

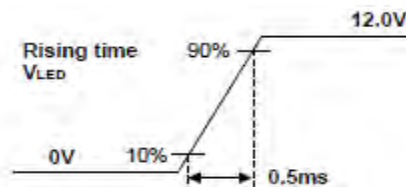

Figure 5. Inrush Measure Condition

3.3 LED Structure

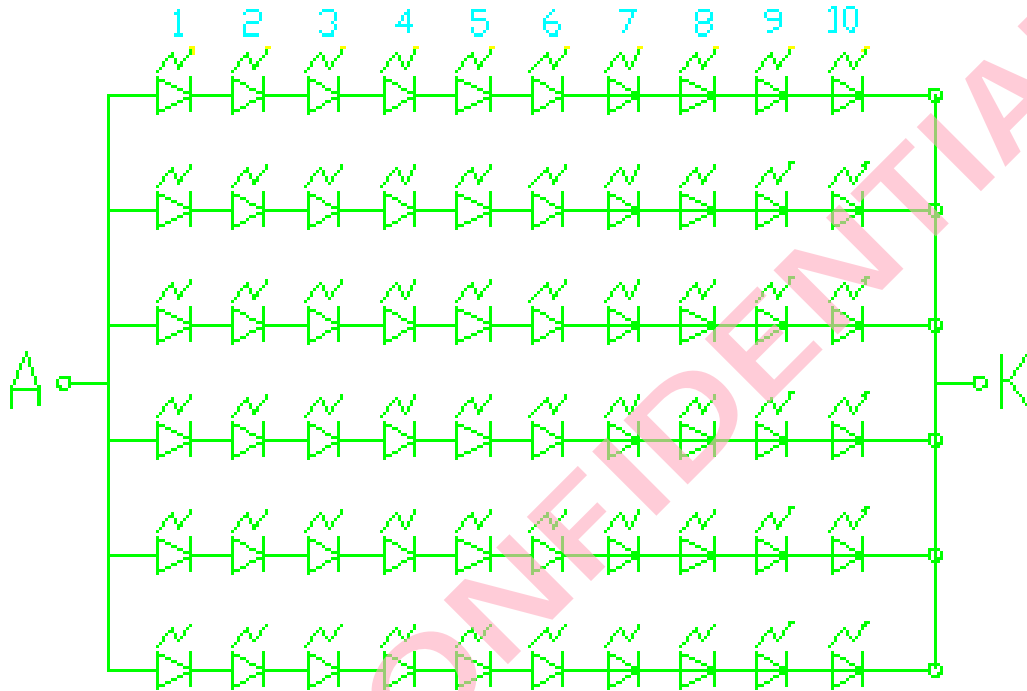

Figure 6. LED Structure

4.0 OPTICAL SPECIFICATION

4.1 Optical Specifications

<Table 5. Optical Specifications>

Parameter		Symbol	Condition	Min.	Typ.	Max.	Unit	Remark
Viewing Angle Range	Horizontal	θ_3	CR > 10	-	85	-	Deg.	Note 1
		θ_9		-	85	-	Deg.	
	Vertical	θ_{12}		-	85	-	Deg.	
		θ_6		-	85	-	Deg.	
Luminance Contrast Ratio		CR	$\theta = 0^\circ$	600	800	-	Deg.	Note 2
Luminance of White	Center	Y_w	$\theta = 0^\circ$ $I_{LED} = 20mA$	340	390	-	cd/m ²	Note 3
White Luminance Uniformity	5 Points	$\Delta Y5$		75	80	-		Note 4
	9 Points	$\Delta Y9$		65	70	-		
White Chromaticity		W_x	$\theta = 0^\circ$	0.288	0.318	0.348		Note 5
		W_y		0.317	0.347	0.377		
Reproduction of Color	Red	R_x	$\theta = 0^\circ$	-0.03	0.593	+0.03		
		R_y			0.369			
	Green	G_x			0.354			
		G_y			0.578			
	Blue	B_x			0.162			
		B_y			0.138			
Color Gamut				-	45	-	%	
Color Temperature			$\theta = 0^\circ$	5150	6150	7150	K	Center

Notes :

1. Viewing angle is the angle at which the contrast ratio is greater than 10. The viewing angles are determined for the horizontal or 3, 9 o'clock direction and the vertical or 6, 12 o'clock direction with respect to the optical axis which is normal to the LCD surface (see Figure 7).

2. Contrast measurements shall be made at viewing angle of $\theta=0$ and at the center of the LCD surface. Luminance shall be measured with all pixels in the view field set first to white, then to the dark (black) state . (see Figure 7) Luminance Contrast Ratio (CR) is defined mathematically.

$$CR = \frac{\text{Luminance when displaying a white raster}}{\text{Luminance when displaying a black raster}}$$

3. Center Luminance of white is defined as luminance values of 5 point average across the LCD surface. Luminance shall be measured with all pixels in the view field set first to white. This measurement shall be taken at the locations shown in Figure 8 for a total of the measurements per display.

4. The White luminance uniformity on LCD surface is then expressed as : $\Delta Y = \text{Minimum Luminance of 5(or 9) points} / \text{Maximum Luminance of 5(or 9) points}$.(see Figure 8 and Figure 9).

5. The color chromaticity coordinates specified in Table 5 shall be calculated from the spectral data measured with all pixels first in red, green, blue and white. Measurements shall be made at the center of the panel.

4.2 Optical Measurements

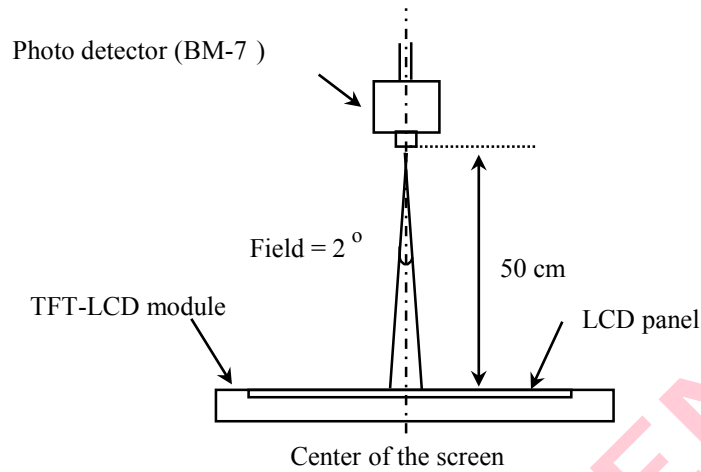

Optical characteristics measurement setup

Figure 7. Measurement Set Up

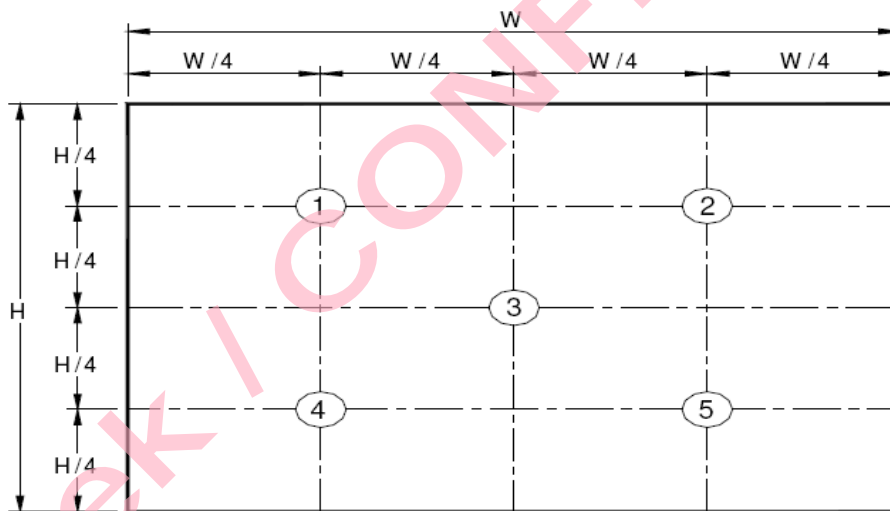

Figure 8. White Luminance and Uniformity Measurement Locations (5 points)

Center Luminance of white is defined as luminance values of center 5 points across the LCD surface. Luminance shall be measured with all pixels in the view field set first to white. This measurement shall be taken at the locations shown in Figure 7 for a total of the measurements per display.

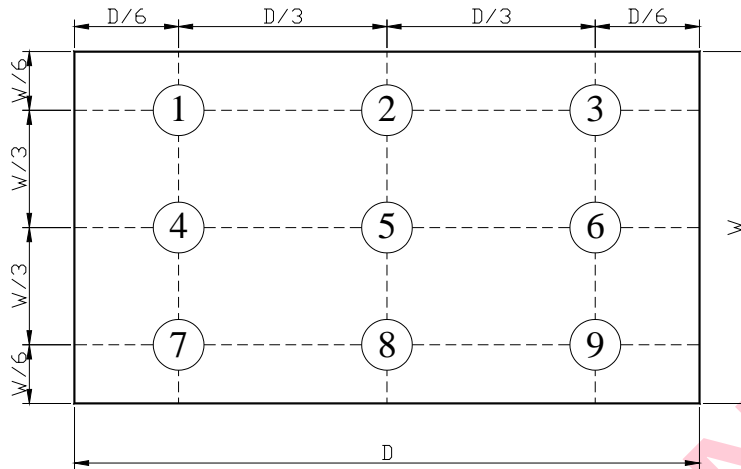

Figure 9. Uniformity Measurement Locations (9 points)

The White luminance uniformity on LCD surface is then expressed as : ΔY_5 = Minimum Luminance of five points / Maximum Luminance of five points (see Figure 8) , ΔY_9 = Minimum Luminance of 9 points /Maximum Luminance of 9 points (see Figure 9).

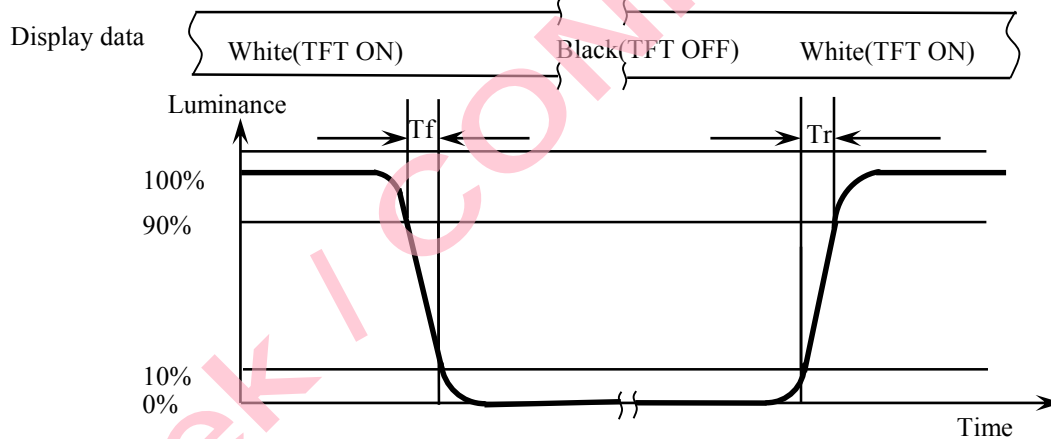

Figure 10. Response Time Testing

The electro-optical response time measurements shall be made as shown in Figure 10 by switching the “data” input signal ON and OFF. Tf: The luminance to change from 90% to 10% ,Tr: The luminanceto change from 10% to 90% .

5.0 INTERFACE CONNECTION

5.1 Connector Description

Physical interface is described as for the connector on LCM.

These connectors are capable of accommodating the following signals and will be following components.

Connector Name /Description	For Signal Connector
Manufacturer	STM
Type/ Part Number	MSAK24025P30
Mating Housing/ Part Number	I-PEX 20454-030T

5.2 Electrical Interface Connection

The electronics interface connector is STM MSAK24025P30 or Compatible.

The connector interface pin assignments are listed in Table 6.

<Table 6. Pin Assignments for the Interface Connector>

Terminal	Symbol	Functions
Pin No.	Symbol	Description
1	CABC_EN	Disable
2	H_GND	Ground
3	LANE1_N	eDP RX Channel 1 Negative
4	LANE1_P	eDP RX Channel 1 Positive
5	H_GND	Ground
6	LANE0_N	eDP RX Channel 0 Negative
7	LANE0_P	eDP RX Channel 0 Positive
8	H_GND	Ground
9	AUX_CH_P	eDP AUX CH Positive
10	AUX_CH_N	eDP AUX CH Negative
11	H_GND	Ground
12	LCD_VCC	Power Supply, 3.3V (typ.)
13	LCD_VCC	Power Supply, 3.3V (typ.)
14	BIST	Panel Self Test Enable
15	H_GND	Ground
16	H_GND	Ground
17	HPD	Hot Plug Detect Output
18	BL_GND	LED Ground
19	BL_GND	LED Ground
20	BL_GND	LED Ground
21	BL_GND	LED Ground
22	BL_ENABLE	LED Enable Pin(+3.3V Input)
23	BL_PWM	System PWM Signal Input
24	NC	No Connection
25	NC	No Connection
26	BL_POWER	LED Power Supply 5V-21V
27	BL_POWER	LED Power Supply 5V-21V
28	BL_POWER	LED Power Supply 5V-21V
29	BL_POWER	LED Power Supply 5V-21V
30	NC	No Connection

5.3 eDP Interface

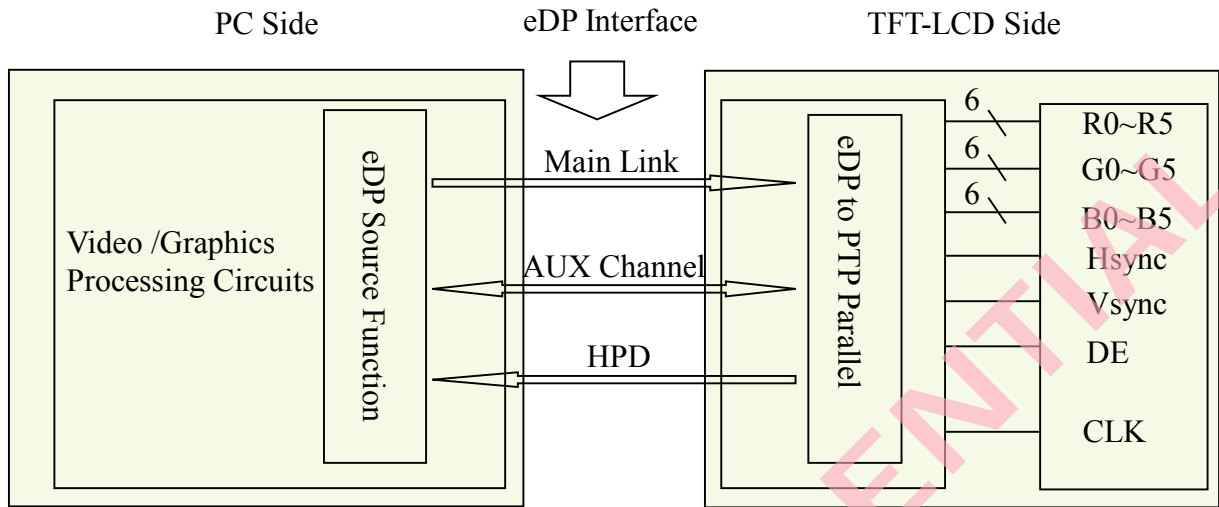

Figure 12. eDP Interface Architecture

Note:

Transmitter : Parade DP501 or equivalent.

Transmitter is not contained in module.

5.4 eDP Mainlink eye diagram test point

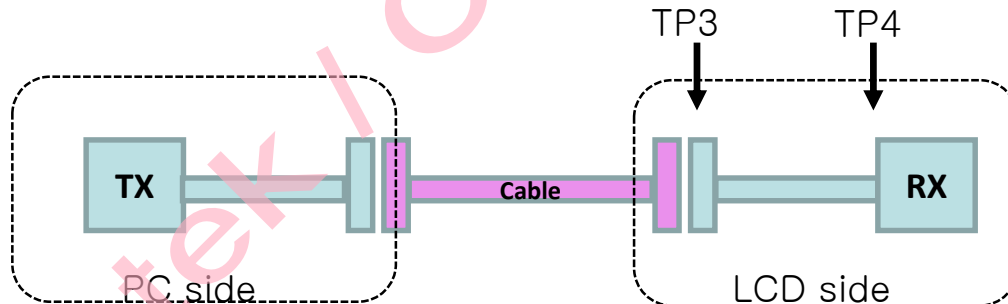

Mainlink eye diagram test point

Notes: Mainlink eye diagram at TP3 needs to be measured on the sink side(LCD Panel). The spec of sink eye vertices at TP3 should follow VESA DisplayPort™ Standard Version1. Revision 1a and Vesa Embedded DisplayPort Standard Version 1.2.

5.5 Data Input Format

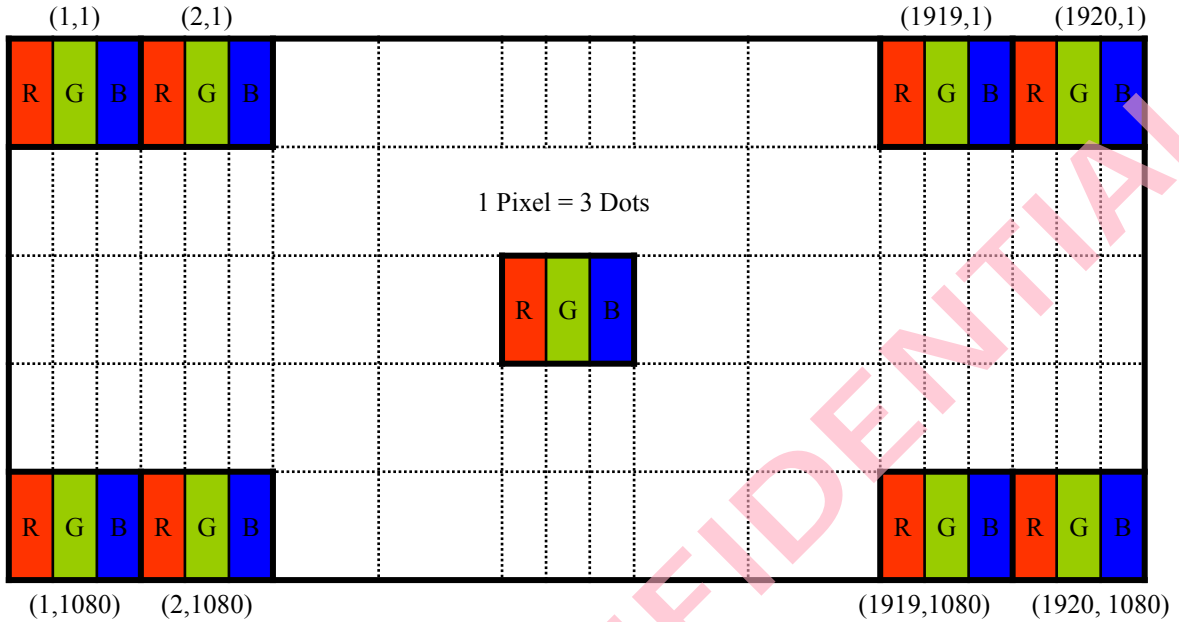

Figure 13. Display Position of Input Data (V-H)

5.6 Back-light & LCM Interface Connection

BLU Interface Connector: STM MSK24022P10 .

<Table 7. Pin Assignments for the BLU Connector>

Pin No.	Symbol	Description	Pin No.	Symbol	Description
1	LED	LED cathode connection	6	LED	LED cathode connection
2	LED	LED cathode connection	7	NC	No Connection
3	LED	LED cathode connection	8	NC	No Connection
4	LED	LED cathode connection	9	Vout	LED anode connection
5	LED	LED cathode connection	10	Vout	LED anode connection

6.0 SPECIFICATION

6.1 Signal Timing Specification

< Table 8.>

Item		Symbols	Min	Typ	Max	Unit
Clock	Frequency	1/Tc	136.65	140.24	147.2	MHz
Frame Period		Tv	1095	1100	1115	lines
			-	60	-	Hz
			-	16.67	-	ms
Vertical Display Period		Tvd	-	1080	-	lines
One line Scanning Period		Th	2080	2124	2200	clocks
Horizontal Display Period		Thd	-	1920	-	clocks

Note : The above is as optimized setting.

6.2 eDP Rx Interface Timing Parameter

The specification of the eDP Rx interface timing parameter is shown in Table 9.

<Table 9. eDP Main-Link RX TP4 Package Pin Parameters>

Item	Symbol	Min	Typ	Max	Unit	Remark
Spread spectrum clock (Link clock down-spreading)	ssc	-	-	0.5	%	
Differential peak-to-peak input voltage at package pins	VRX-DIFFp-p	100	-	1320	mV	
Rx input DC common mode voltage	VRX_DC_CM	0	-	2	V	
Differential termination resistance	RRX-DIFF	80	100	120	Ω	
Single-ended termination resistance	RRX-SE	40	-	60	Ω	
Rx short circuit current limit	IRX_SHORT	-	-	50	mA	
Intra-pair skew at Rx package pins (HBR) RX intra-pair skew tolerance at HBR	LRX_SKEW_ INTRA_PAIR	-	-	60	ps	

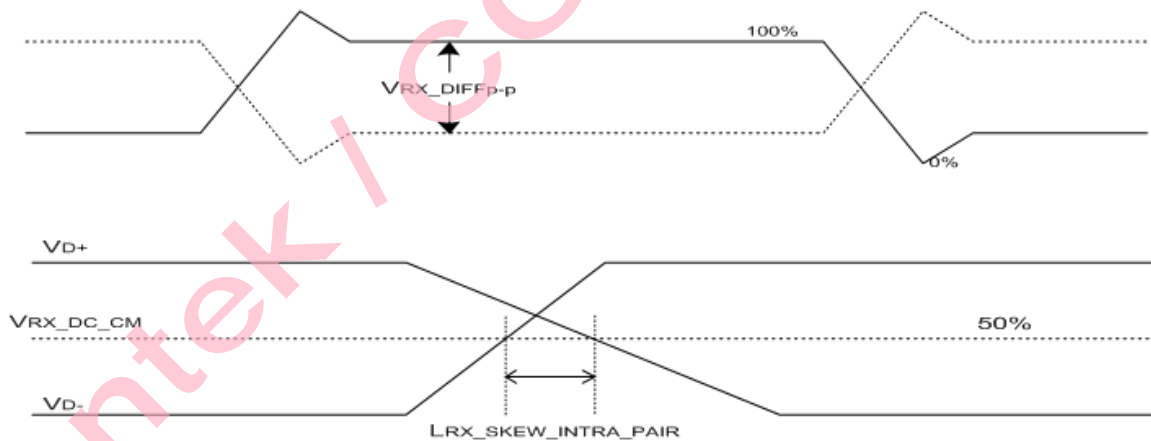

Figure 14. VRX-DIFFp-p & LRX_SKEW_INTRA_PAIR

7.0 INPUT SIGNALS, BASIC DISPLAY COLORS & GRAY SCALE OF COLORS

	Colors & Gray scale	Data signal																	
		R0	R1	R2	R3	R4	R5	G0	G1	G2	G3	G4	G5	B0	B1	B2	B3	B4	B5
Basic colors	Black	0	0	0	0	0	0	0	0	0	0	0	0	0	0	0	0	0	0
	Blue	0	0	0	0	0	0	0	0	0	0	0	0	1	1	1	1	1	1
	Green	0	0	0	0	0	0	1	1	1	1	1	1	0	0	0	0	0	0
	Light Blue	0	0	0	0	0	0	1	1	1	1	1	1	1	1	1	1	1	1
	Red	1	1	1	1	1	1	0	0	0	0	0	0	0	0	0	0	0	0
	Purple	1	1	1	1	1	1	0	0	0	0	0	0	1	1	1	1	1	1
	Yellow	1	1	1	1	1	1	1	1	1	1	1	1	0	0	0	0	0	0
	White	1	1	1	1	1	1	1	1	1	1	1	1	1	1	1	1	1	1
Gray scale of Red	Black	0	0	0	0	0	0	0	0	0	0	0	0	0	0	0	0	0	0
	△ Darker	1	0	0	0	0	0	0	0	0	0	0	0	0	0	0	0	0	0
	▽ Brighter	0	1	0	0	0	0	0	0	0	0	0	0	0	0	0	0	0	0
	△ ▽																		
	▽ Brighter	1	0	1	1	1	1	0	0	0	0	0	0	0	0	0	0	0	0
	▽ Red	0	1	1	1	1	1	0	0	0	0	0	0	0	0	0	0	0	0
Gray scale of Green	Black	0	0	0	0	0	0	0	0	0	0	0	0	0	0	0	0	0	0
	△ Darker	0	0	0	0	0	0	1	0	0	0	0	0	0	0	0	0	0	0
	▽ Brighter	0	0	0	0	0	0	0	1	0	0	0	0	0	0	0	0	0	0
	△ ▽																		
	▽ Brighter	0	0	0	0	0	0	1	0	1	1	1	1	0	0	0	0	0	0
	▽ Green	0	0	0	0	0	0	0	1	1	1	1	1	0	0	0	0	0	0
Gray scale of Blue	Black	0	0	0	0	0	0	0	0	0	0	0	0	0	0	0	0	0	0
	△ Darker	0	0	0	0	0	0	0	0	0	0	0	0	1	0	0	0	0	0
	▽ Brighter	0	0	0	0	0	0	0	0	0	0	0	0	0	1	0	0	0	0
	△ ▽																		
	▽ Brighter	0	0	0	0	0	0	0	0	0	0	0	0	1	0	1	1	1	1
	▽ Blue	0	0	0	0	0	0	0	0	0	0	0	0	0	1	1	1	1	1
Gray scale of White & Black	Black	0	0	0	0	0	0	0	0	0	0	0	0	0	0	0	0	0	0
	△ Darker	1	0	0	0	0	0	1	0	0	0	0	0	1	0	0	0	0	0
	▽ Brighter	0	1	0	0	0	0	0	1	0	0	0	0	0	1	0	0	0	0
	△ ▽																		
	▽ Brighter	1	0	1	1	1	1	1	0	1	1	1	1	1	0	1	1	1	1
	▽ White	0	1	1	1	1	1	0	1	1	1	1	1	0	1	1	1	1	1
White	1	1	1	1	1	1	1	1	1	1	1	1	1	1	1	1	1	1	

8.0 POWER SEQUENCE

To prevent a latch-up or DC operation of the LCD module, the power on/off sequence shall be as shown in below.

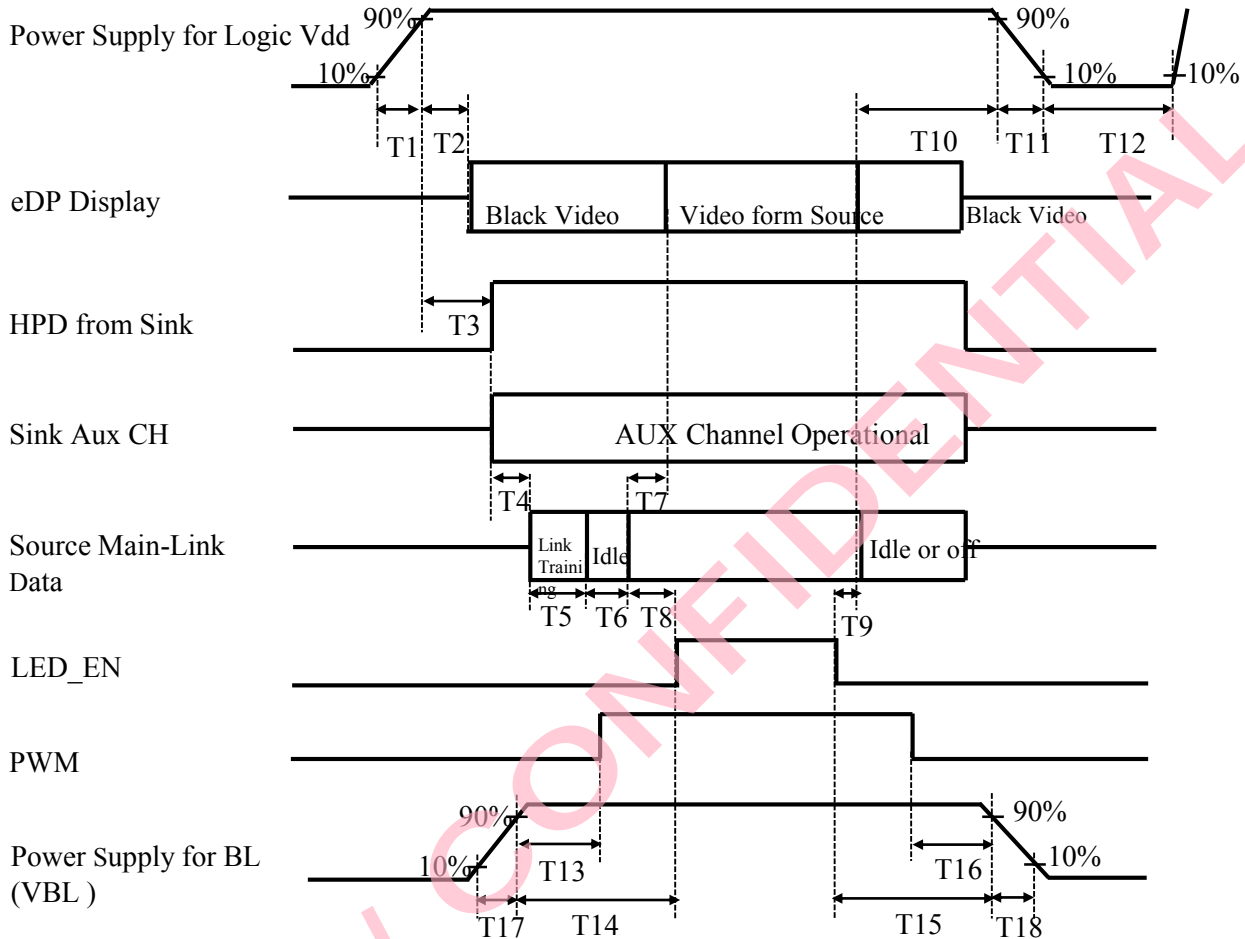

Figure 15. Power Sequence

- $0.5\text{ms} \leq T1 \leq 10\text{ms}$
- $0\text{ms} < T2 \leq 200\text{ms}$
- $0\text{ms} < T3 \leq 200\text{ms}$
- $T3+T4+T5+T6+T8 > 200\text{ms}$
- $0\text{ms} < T7 \leq 50\text{ms}$
- $T7 < T8$
- $0\text{ms} < T9$
- $0\text{ms} < T10 < 500\text{ms}$
- $0.5\text{ms} \leq T11 \leq 10\text{ms}$
- $500\text{ms} \leq T12$
- $0\text{ms} < T13$
- $0\text{ms} < T14$
- $0\text{ms} < T15$
- $0\text{ms} < T16$
- $0.5\text{ms} \leq T17$
- $0.5\text{ms} \leq T18$

Notes:

1. When the power supply VDD is 0V, keep the level of input signals on the low or keep high impedance.
2. Do not keep the interface signal high impedance when power is on. Back Light must be turn on after power for logic and interface signal are valid.

9. MECHANICAL DRAWING

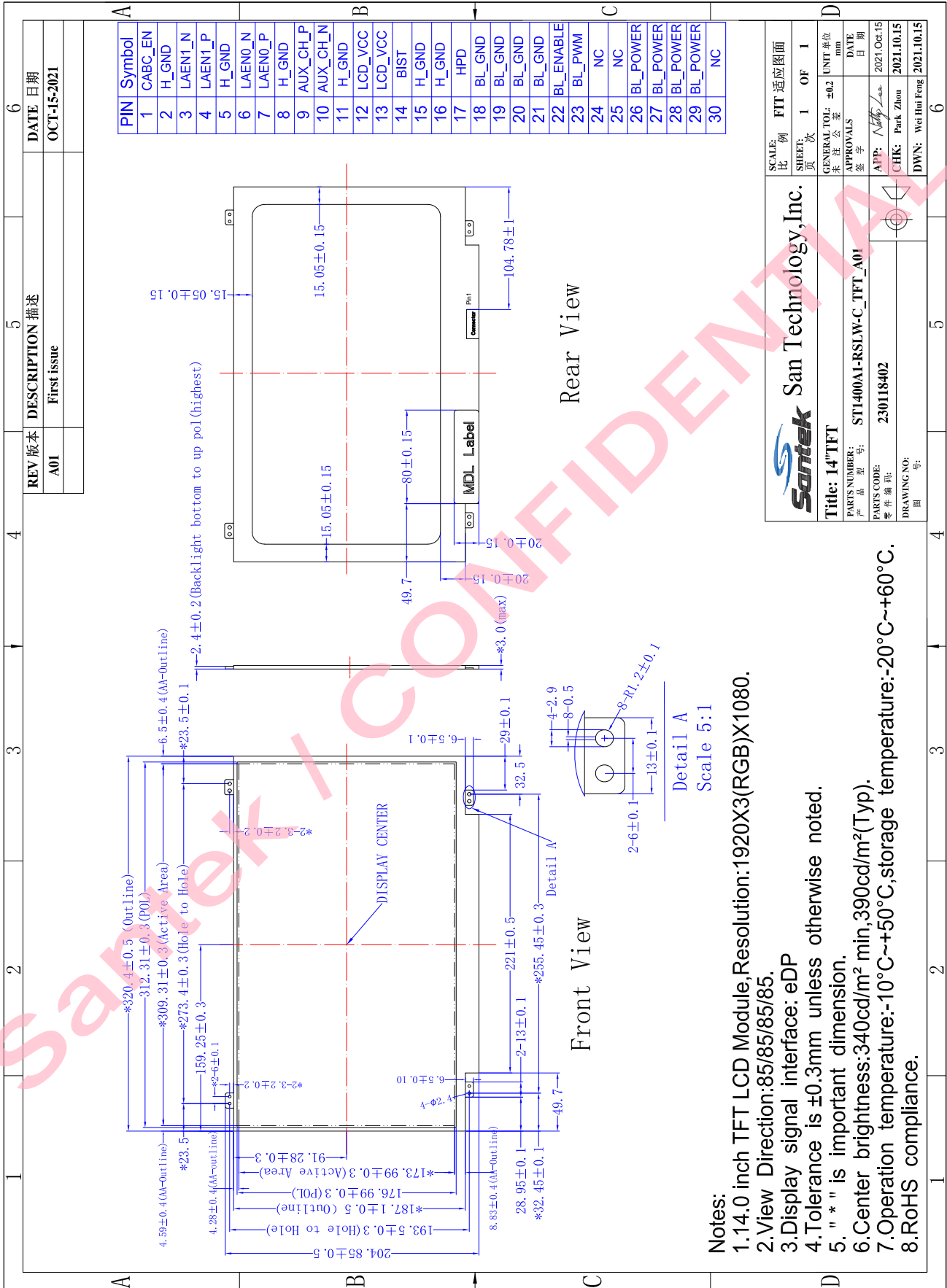

**10. PACKAGE DRAWING
(TBD)**

Santek | CONFIDENTIAL

11.0 RELIABILITY TEST

The reliability test items and its conditions are shown in below.

<Table 13. Reliability Test>

No	Test Items	Conditions
1	High temperature storage test	Ta = 60°C , 60%RH, 240 hrs
2	Low temperature storage test	Ta = -20°C , 240 hrs
3	High temperature & high humidity operation test	Ta = 50°C , 80%RH, 240 hrs
4	High temperature operation test	Ta = 50°C , 60%RH, 240 hrs
5	Low temperature operation test	Ta = 0°C , 240 hrs
6	Thermal shock	Ta = -20 °C ↔ 60 °C (0.5 hr), 60% ± 3%RH, 100 cycle
7	Vibration test (non-operating)	Ta = 25°C , 60%RH, 1.5G, 10~500Hz, Sine X,Y,Z / Sweep rate : 1 hour
8	Shock test (non-operating)	Ta = 25°C , 60%RH, 220G, Half Sine Wave 2msec ± X, ± Y, ± Z Once for each direction
9	Electro-static discharge test (operating)	Air : 150 pF, 330Ω, 15 KV Contact : 150 pF, 330Ω, 8 KV Ta = 25°C , 60%RH,

12.0 HANDLING & CAUTIONS

- (1) Cautions when taking out the module
 - Pick the pouch only, when taking out module from a shipping package.
- (2) Cautions for handling the module
 - As the electrostatic discharges may break the LCD module, handle the LCD module with care. Peel a protection sheet off from the LCD panel surface as slowly as possible.
 - As the LCD panel and back - light element are made from fragile glass material, impulse and pressure to the LCD module should be avoided.
 - As the surface of the polarizer is very soft and easily scratched, use a soft dry cloth without chemicals for cleaning.
 - Do not pull the interface connector in or out while the LCD module is operating.
 - Put the module display side down on a flat horizontal plane.
 - Handle connectors and cables with care.
- (3) Cautions for the operation
 - When the module is operating, do not lose CLK, ENAB signals. If any one of these signals is lost, the LCD panel would be damaged.
 - Obey the supply voltage sequence. If wrong sequence is applied, the module would be damaged.
- (4) Cautions for the atmosphere
 - Dew drop atmosphere should be avoided.
 - Do not store and/or operate the LCD module in a high temperature and/or humidity atmosphere. Storage in an electro-conductive polymer packing pouch and under relatively low temperature atmosphere is recommended.
- (5) Cautions for the module characteristics
 - Do not apply fixed pattern data signal to the LCD module at product aging.
 - Applying fixed pattern for a long time may cause image sticking.
- (6) Other cautions
 - Do not disassemble and/or re-assemble LCD module.
 - Do not re-adjust variable resistor or switch etc.
 - When returning the module for repair or etc. Please pack the module not to be broken. We recommend to use the original shipping packages.