

DETAIL X

DESCRIPTION	DATE	APPD
	10/17/2009	

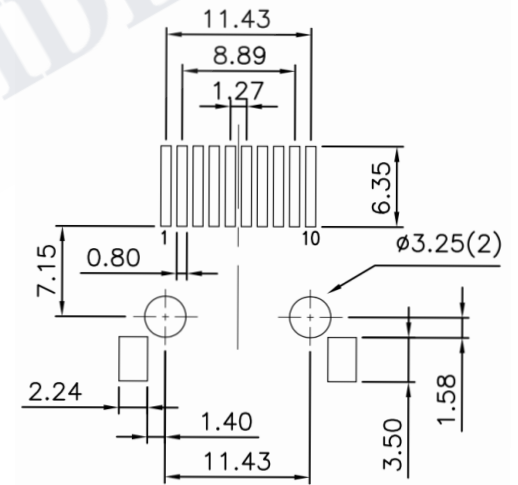
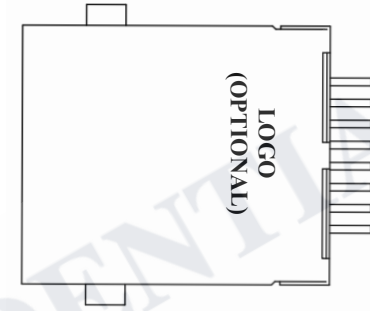

PCB LAYOUT

Ref.

NOTES:
CAVITY CONFIRMS TO FCC RULES AND REGULATION PART 68, SUBPART F.

CONNECTOR MATERIALS:
1. HOUSING: DSM STANLY TE250F6 (NYLON-46), HEAT DEFLECTION TEMP. 290°, BLACK COLOR, UL94V-0

2. CONTACTS : 0.35mm THICK PHOSPHOR BRONZE PLATED WITH 6µ" HARD GOLD AND GOLD FLASH IN SOLDER AREA.

3. SHELL: 0.2mm THICK COPPER ALLOY, PLATED WITH NICKEL.



X:X ±0.30	APPD: Jessie	TELEWIRE TECHNOLOGY CO., LIMITED
X:XX ±0.25	CHKD: Kevin	
X:XXX ±0.05	DR: Michael	Surface Mount RJ45 Connector without Integrated Magnetics, Side Entry
ANGLES ±1°	UNIT: mm	PART NO. : TWE088921925S1LFG
	SCALE: 2/1	SHEET: 2/2
	REV: A	DWG NO. : TWE088921925S1LFG