

The Mantis Solar Security Light is a high-performance lighting solution designed to provide efficient and reliable illumination for both wall-mounted and flood light applications. Featuring dual adjustable lamp heads, PIR motion sensing, and customizable lighting modes, this light is perfect for a variety of outdoor environments such as pathways, gardens, facades, and security lighting.

Specifications

Lumens..... 800LM (left/right lamp head 400LM each)

Solar Panel

Power Monocrystalline silicon, 4.4V/ 1.3W

Li-ion battery

Capacity 3.7V 7.4WH

Charging / Discharging Temp 6.8 °F ~ 131 °F

Charging Time ≤7H

LED 2835, 24pcs (12pcs each for left/right lamp heads)

CCT 4000K, Ra>70

Efficiency 160lm/W

Types of Lighting T2S

Performance

Lighting Time in Rainy day >3 days

Core Technology ALS2.4

PIR..... 120°, 5m.Max

IP Class IP44

Lighting Area 20m²

Install Height / Distance 8.2 / 19.6Ft

Material..... ABS

Dimensions

Product Size 5.4*4.1*2.1 In

Weight 0.77 Lbs

Model Number..... MANTIS SWL 39

SKU..... 790116

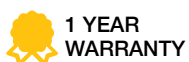

Beyond Solar retains the right to modify or change product specifications without prior notice, as part of our ongoing commitment to improvement.

Double lamp head, can adjust the lighting angle.



Lighting mode and brightness can be customized by you.

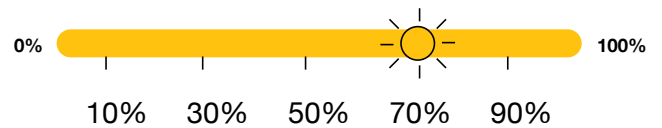

Lighting Mode

- M1: 20% till dawn
- M2: 10% PIR (30S) till dawn
- M3: 0% PIR (30S) till dawn
- M4: 100% till dawn

Indicator Light

- M1: Lamp flashes 1 time
- M2: Lamp flashes 2 times
- M3: Lamp flashes 3 times
- M4: Lamp flashes 4 times

Switch

1. ON and OFF: long press for 1.5S
2. Short press to switch the lighting mode
3. Long press for 6s to reset
4. In any mode, can adjust the brightness, two short clicks of the button, brightness will increase 10%

Diverse installation methods

Support cable tie and wall mounted by screws. Also Magnetic installation accessory is optional.



Cable tie installation



Wall Mounted by Screws



Magnetic installation is optional

Beyond Solar retains the right to modify or change product specifications without prior notice, as part of our ongoing commitment to improvement.



23% charging efficiency

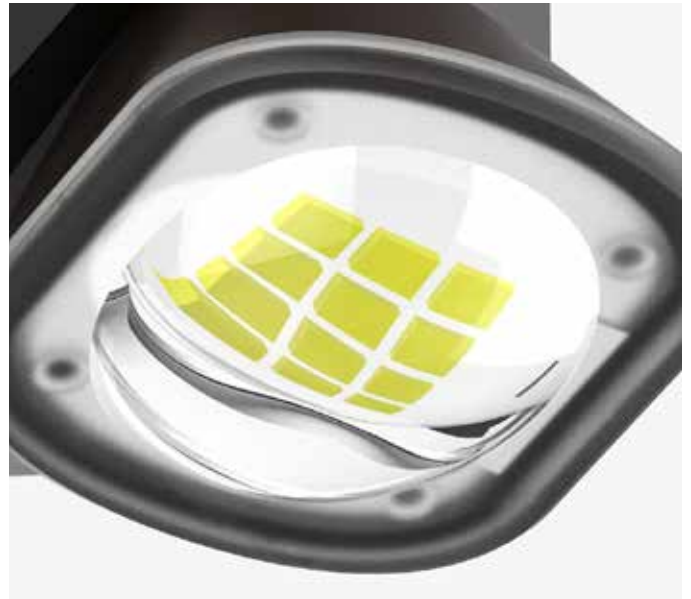

High lumen LEDs 160lm/W



PIR: 120°, 5m.Max



Bracket

Beyond Solar retains the right to modify or change product specifications without prior notice, as part of our ongoing commitment to improvement.

Dimensions

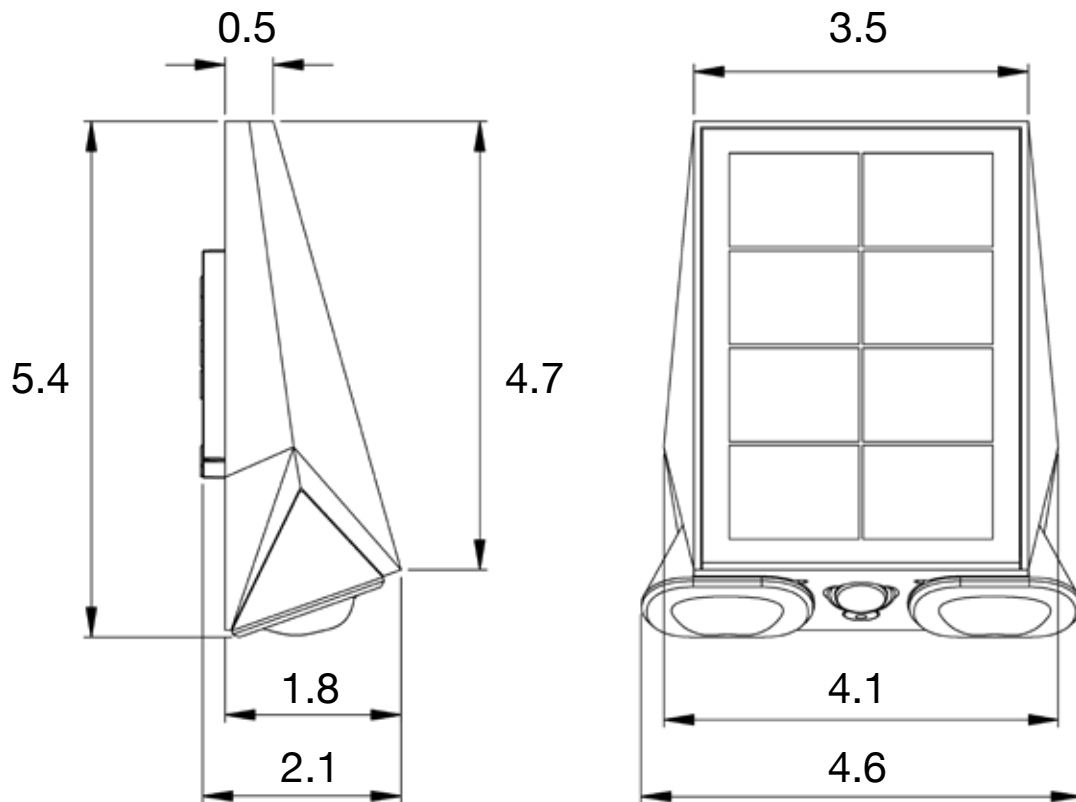

*All Dimensions are in Inches (in)

Package



LAMP 1 PC
INSTRUCTIONS: 1 PC
SCREW: 1 SET



1 PC
/ 1 BOX



42 PCS
/ CARTON

PACKING METHOD	PCS/CTN	QTY(PCS)	CTN QTY	CARTON SIZE(IN)	N.W(LBS)	G.W(LBS)
Inner Box	1	1	1	4.8x2.2x5.8	0.66	0.66
Carton	42	42	1	16.5x15.1x12.4	27.7	35

Net weight and gross weight are for reference only

Beyond Solar retains the right to modify or change product specifications without prior notice, as part of our ongoing commitment to improvement.

Mantis | Security Light



Beyond Solar retains the right to modify or change product specifications without prior notice, as part of our ongoing commitment to improvement.